

# 37 12 070 Removing and installing/replacing rear left or right air suspension strut (Flat rate unit without wheel alignment)

## Overview of Activities

### Additional Information

#### Preliminary Work

- 1 Creating a fault memory printout in warranty cases
- 2 Deactivating the air spring system
- 3 Removing the luggage compartment floor trim panel
- 4 If installed: Removing the third-row seating (additional work: FRU no.: 33 52 991)
- 5 Removing the rear left wheel
- 6 Removing the cover of the camber control arm
- 7 Removing the camber control arm
- 8 Disconnecting the plug connection on the spring strut

#### Main Work

- 9 Removing the rear air suspension strut 
- 10 Replacement: Renewing the rear air suspension strut
- 11 Installing the rear air suspension strut

#### Postprocesses

- 12 Connecting the connector to spring strut
- 13 Installing the camber control arm
- 14 Installing the rear left wheel
- 15 If installed: Install the third-row seating (additional work flat rate unit number: 33 52 991)
- 16 Installing the luggage compartment floor trim panel
- 17 Activating and filling the air suspension system
- 18 Measuring the ride height of rear axle and adjusting the normal position
- 19 Tightening the screw connections on the camber control arm
- 20 Installing the cover of the camber control arm

[Additional information is available.](#)

### General information

#### RISK OF DAMAGE

##### Damage to the air suspension strut.

**Moving the vehicle when the air suspension struts are not completely filled will result in damage to the air suspension strut.**

- Make sure the air suspension struts are completely filled. The residual pressure in the air suspension strut is not sufficient.
- Activate and fill air spring system to enable movement of the vehicle.

## RISK OF DAMAGE

### Contaminant or foreign body.

Contamination can result in malfunction, operating failure or leak.

- Adhere to the utmost cleanliness.
- Protect components from contamination, e.g., by covering.
- Seal off cable connections with seal plugs.

## RISK OF DAMAGE

### Damage to the air spring system.

Even the smallest of dirt particles can cause leakage in the air suspension system.

- Ensure utmost cleanliness within the connection face of the pipes during disassembly and installation.
- For this purpose, also see the additional information: 37 00 ... Information for the air spring system.

## TECHNICAL INFORMATION

Perform wheel alignment after installation.

## PRELIMINARY WORK

### 1–Creating a fault memory printout in warranty cases

## TECHNICAL INFORMATION

In a warranty case, you must always provide a fault memory printout with the defective part, even if the fault memory does not contain an entry.



- Prepare fault memory printout.
- Attach the fault memory printout to the damaged part.

### 2–Deactivating the air spring system

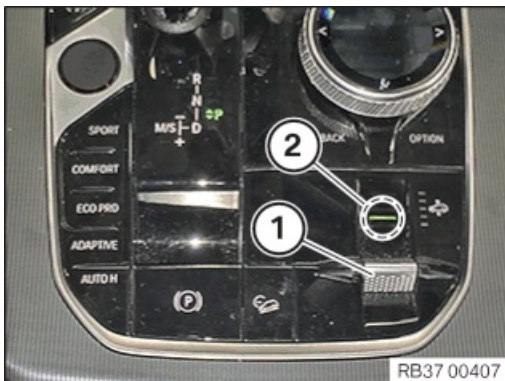

- Switch the ignition on.
- Press self-levelling suspension button (1) for 7 s and then release it.  
Upon successful deactivation, the indicator light for air spring system (self-levelling suspension) (2) goes out.
- Note** Pressing the self-levelling suspension button (1) for a longer or shorter duration does not : cause the air spring system to deactivate.
- Switch off ignition.

### 3–Removing the luggage compartment floor trim panel

## TECHNICAL INFORMATION

Different versions may be installed depending on the vehicle equipment.



- Unlock the luggage compartment floor trim panel (1) at the handle (2), slightly lift and remove towards the rear from the latch mechanisms (3).

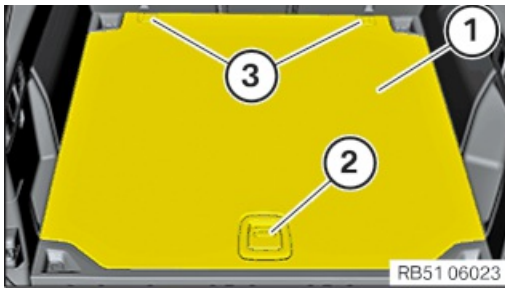

### ► Removing luggage compartment floor trim panel (electrical roller cover for luggage compartment)

#### Prerequisite

The electrical roller cover for luggage compartment must be at the top. Raise it if necessary.

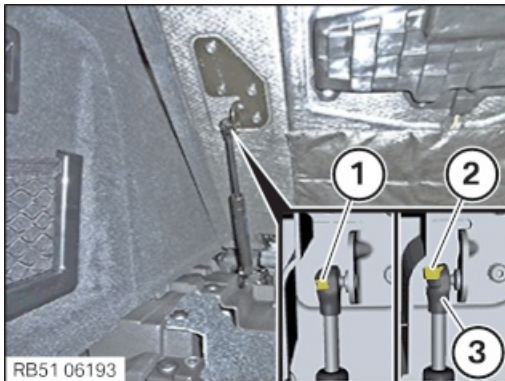

- Raise luggage compartment floor trim.

#### NOTICE

Perform the steps on the left and right side.

- Slide clamp (1) to position (2) to remove.
- Pull off gas pressure spring (3) from the ball head.

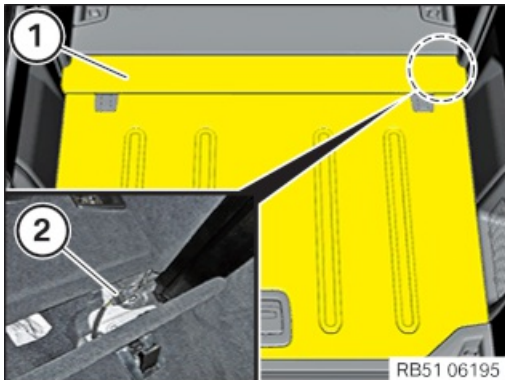

- Fold up lid (1) and unlock and disconnect plug connection (2).

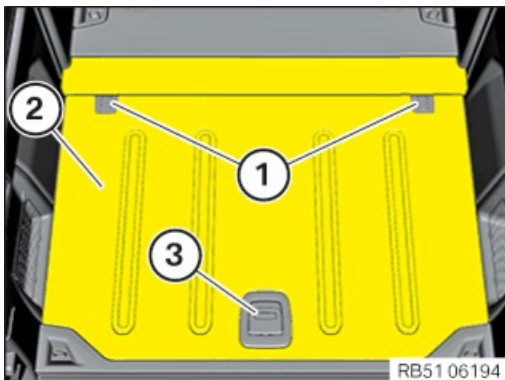

- Open the covers (1) and unscrew the bolts below it.
- Unlock luggage compartment floor trim panel (2) at handle (3), lift it slightly, guide it out towards the rear and remove it from the vehicle.



### ► Removing the luggage compartment floor trim panel (with 3rd row of seats)



- Remove covers (1) and release the screws underneath them.
- Unlock luggage compartment floor trim panel (2) at handle (3), lift it slightly, guide it out towards the rear and remove it from the vehicle.

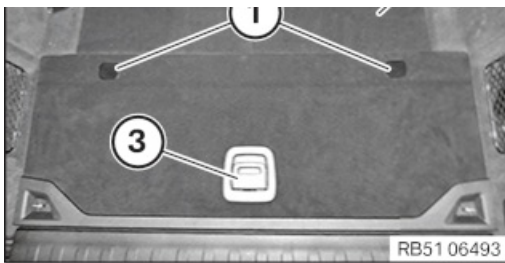

#### 4-If installed: Removing the third-row seating (additional work: FRU no.: 33 52 991)

##### RISK OF DAMAGE

Careless handling of tools and sharp-edged components.

Scratch, surface damage.

- Protect working area.
- Handle tools and components carefully.

##### ► Removing the battery cover

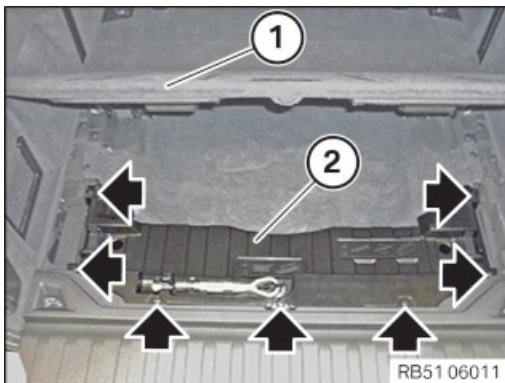

- Fold up luggage compartment floor trim panel (1).
- Release the expanding rivets (arrows) and remove battery cover (2).

##### ► Removing the loading edge trim

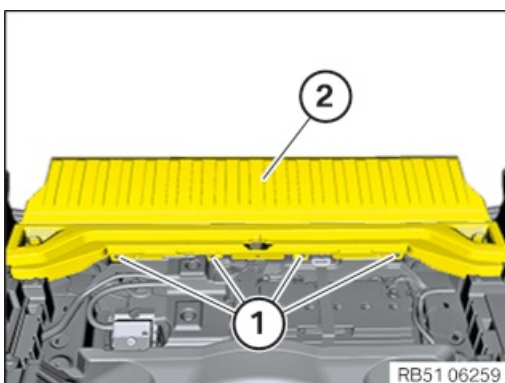

- Loosen screws (1).
- Thread out and remove loading edge trim (2).

##### ► Removing left luggage compartment wheel arch trim panel (with 3rd row of seats)



- Lever out covers (1) using special tool 2 298 505 to the top and guide them out.

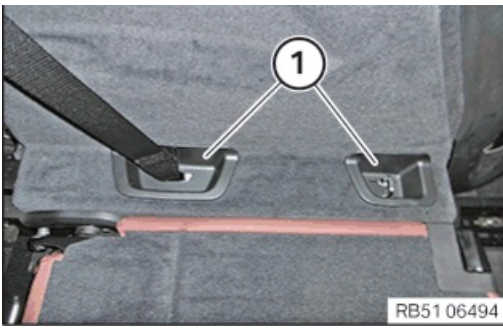

RB51 06494

- Unscrew the screw (1) and remove the end fitting.

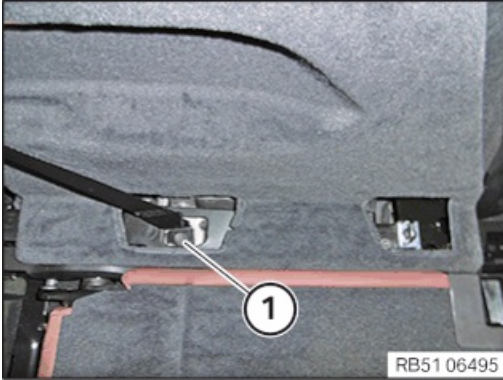

RB51 06495

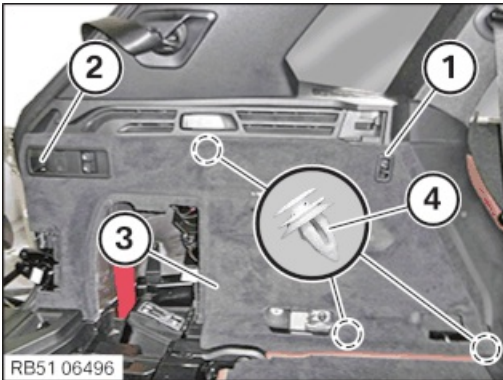

RB51 06496

- Loosen screw (1).
- Remove the cover (2) and release the underlying bolt.
- Release luggage compartment wheel arch trim panel (3) from clips (4) to the top.

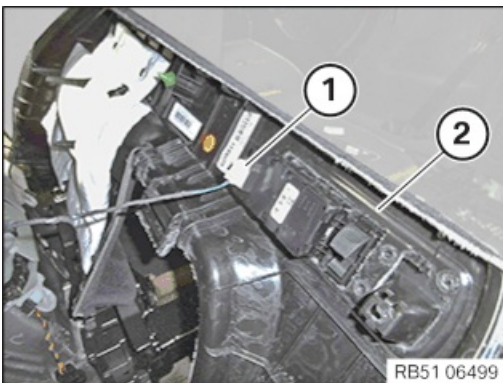

RB51 06499

- Unlock plug connection (1) and disconnect.
- Feed out and remove the luggage compartment wheel arch trim panel (2) towards the rear at the tailgate lock.

▶ Remove 3rd row of seats

**RISK OF DAMAGE**

Careless handling of tools and sharp-edged components.

Scratch, surface damage.

- Protect working area.
- Handle tools and components carefully.



**NOTICE**

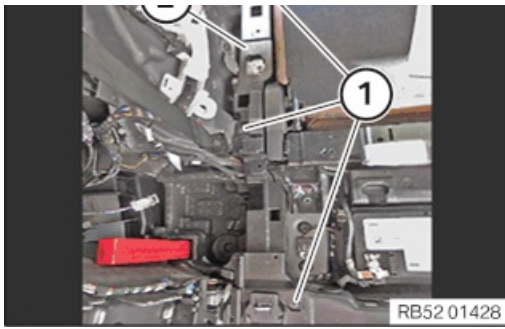

Perform the steps on the left and right side.

- Loosen screws (1).
- Remove the cover (2) of the side member.

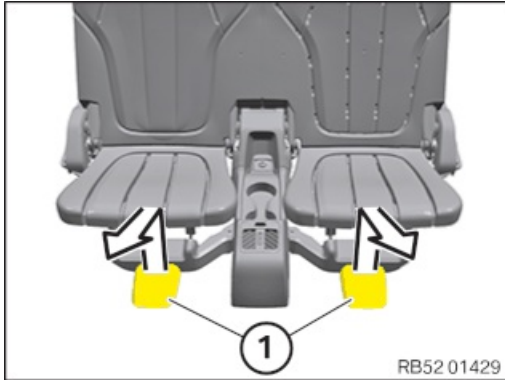

- Remove the seat rail covers (1) in the direction of the arrow.

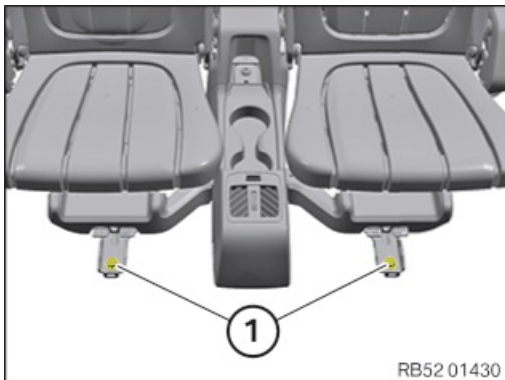

- Loosen screws (1).

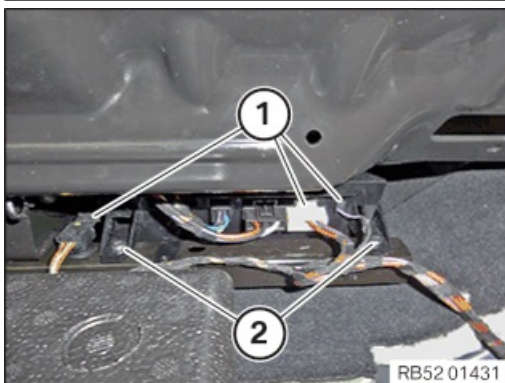

- Unlock and disconnect plug connections (1).

**Note** Plug connections are located on the right underside of the third-row seating and can be reached via the luggage compartment floor covering.

- Unclip the cable clip (2).

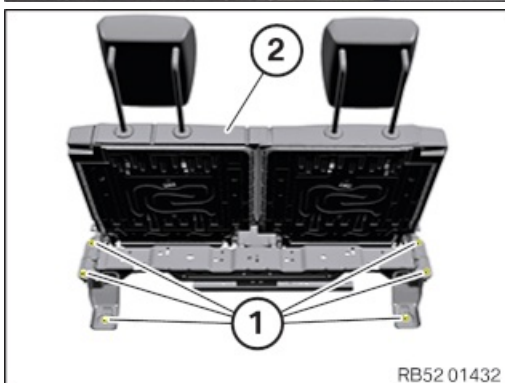

- Loosen screws (1).

**RISK OF DAMAGE**

**Heavy component.**

**Heavy components can lead to injury or damage.**

- Remove and install heavy components with the aid of another person/other persons.

- Remove the third-row seating (2) with the help of an auxiliary person.

**NOTICE**

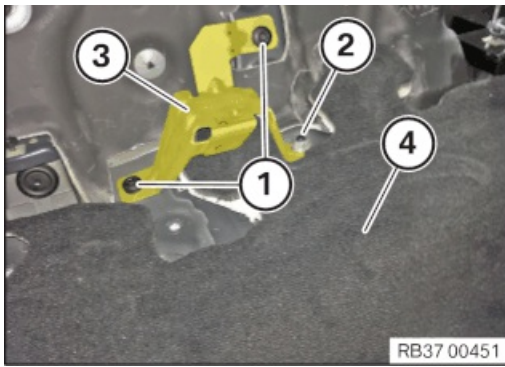

RB37 00451

**NOTICE**

Description is for left component only. Procedure on the right side is identical.

- Unscrew the bolts (1) and the nut (2).
- Remove holder (3).
- Raise the luggage compartment floor trim panel (4).

**5–Removing the rear left wheel**

P04 04 001



RB36 00039

**i TECHNICAL INFORMATION**

A wheel lift is recommended for easier wheel removal and installation without exertion (see Retailer Equipment Catalogue).

- Provide wheel lift.
  - If several wheels are removed simultaneously: Use a piece of chalk to mark on each tyre the axle and side on which the corresponding wheel is fitted.
  - Loosen the wheel bolts (arrows) crosswise and remove the wheel.
- Use the matching adapter from tool set **0 492 518 (36 1 300)** (wheel bolt adapter set) to loosen and tighten the wheel bolt with security code.

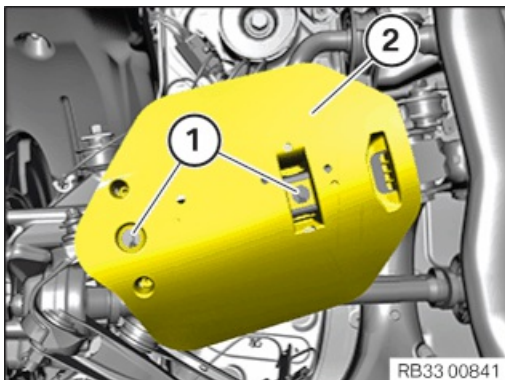
**6–Removing the cover of the camber control arm**

RB33 00841

- Loosen screws (1).
- Pull the cover (2) out and remove it.

**7–Removing the camber control arm**

- Release the nut (1) and remove eccentric washer.

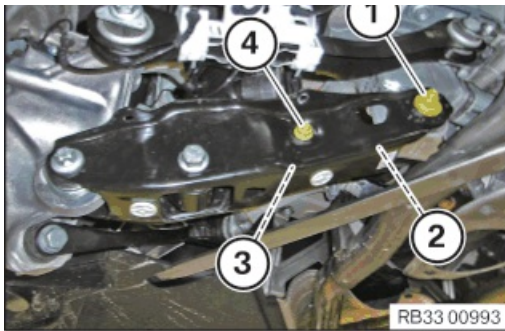

- Pull out the eccentric bolt (1).
- Release nut (4).
- Pull out screw (3) to the front.

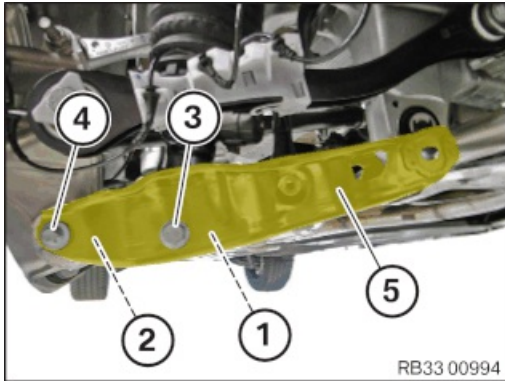

- Loosen nuts (1) and (2).
- Pull out screws (3) and (4).
- Remove the camber arm (5).

## 8–Disconnecting the plug connection on the spring strut

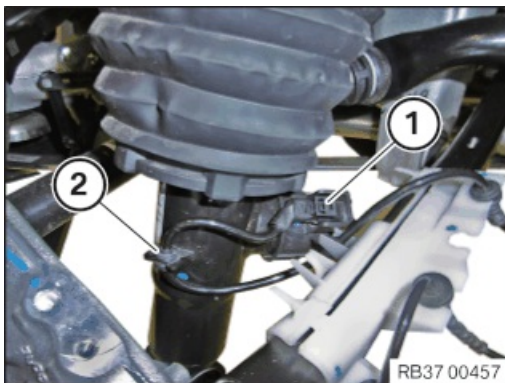

- Unlock and disconnect the plug connection (1) on the spring strut.
- Release cable from holder (2).

### MAIN WORK

## 9–Removing the rear air suspension strut

[Additional information is available.](#)

### ⚠ CAUTION

#### Residual pressure in the air suspension strut.

#### Danger of injury!

- The air suspension strut remains under a certain amount of residual pressure after the pipe has been connected.
- Do not disassemble the air suspension strut.

### 🔧 RISK OF DAMAGE

#### Damage to the air spring system.

#### Even the smallest of dirt particles can cause leakage in the air suspension system.

- Ensure utmost cleanliness within the connection face of the pipes during disassembly and installation.
- For this purpose, also see the additional information: 37 00 ... Information for the air spring system.



- **If installed:**  
Loosen the clips (1).

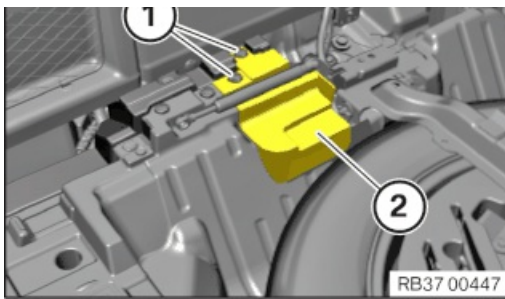

Remove side member cover (2).

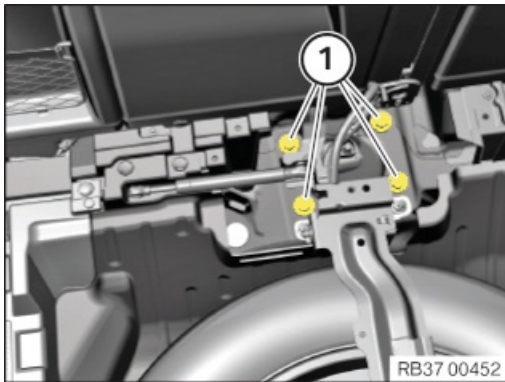

**RISK OF DAMAGE**

**Failure to comply with the specifications.**

**Component damage.**

- All specifications **must** be observed and complied with.

**TECHNICAL INFORMATION**

Secure component against falling.

- Loosen screws (1).

**Note** Secure the air suspension strut from falling down with the help of a second person.

:

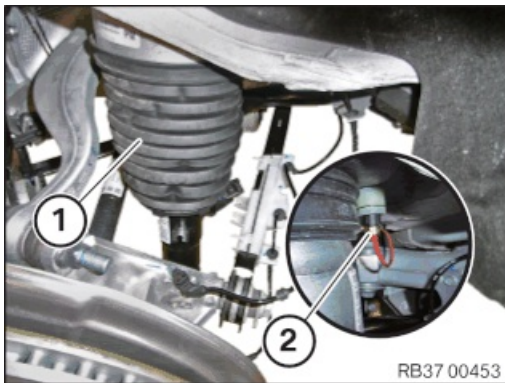

- Lower the air suspension strut slightly (1) to reach the banjo bolt (2).
- Carefully slacken the banjo bolt (2) until escaping air can be heard (hissing).
- Wait approximately 2 minutes until the pressure in the air spring system has been completely reduced.

The fizzing noise stops.

- Completely loosen the banjo bolt (1) after having fully bled the pressure from the system.

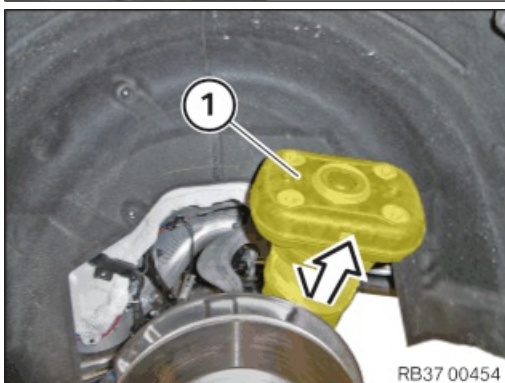

- Carefully guide out the air suspension strut (1) in direction of arrow and remove.

**10-Replacement: Renewing the rear air suspension strut**

- Renew the air suspension strut.

**Parts:** Rear air suspension strut

**11-Installing the rear air suspension strut**

[Additional information is available.](#)



- When reusing (if installed): Release the assembly ring (1) from the air suspension strut (2) and dispose of it.

**Note** Assembly ring (1) is no longer installed.

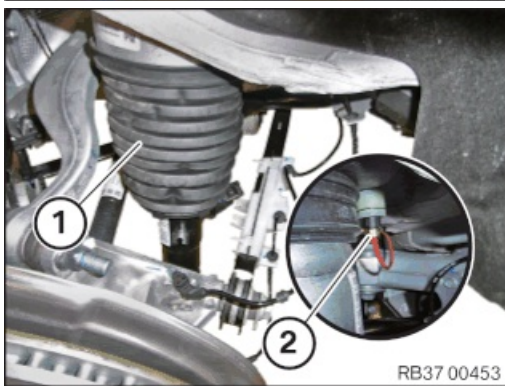
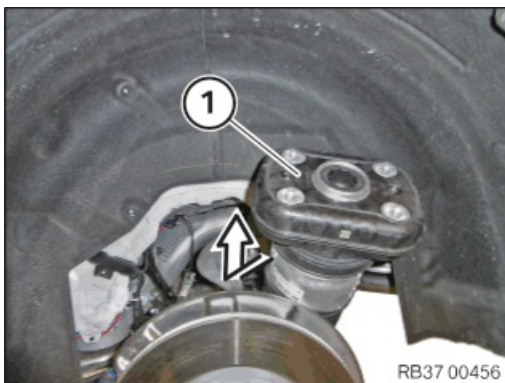
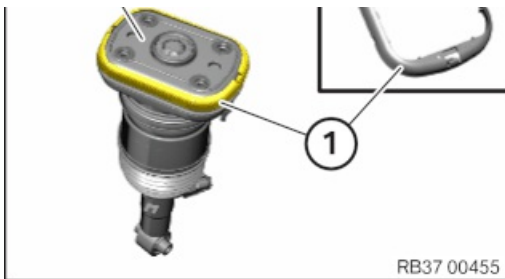

**RISK OF DAMAGE**

**Failure to comply with the specifications.**

**Component damage.**

- All specifications **must** be observed and complied with.

- Carefully guide in the air suspension strut (1) in the direction of the arrow.

**TECHNICAL INFORMATION**

Secure component against falling.

- Check banjo bolt (2) for contamination; clean if necessary.
- Carefully screw in the banjo bolt (2) into the air suspension strut (1) by hand to prevent damage to the thread on the air suspension strut (1).
- Tighten the banjo bolt (1).

**Air line to air suspension strut**

	Tightening torque	2.25 Nm
--	-------------------	---------

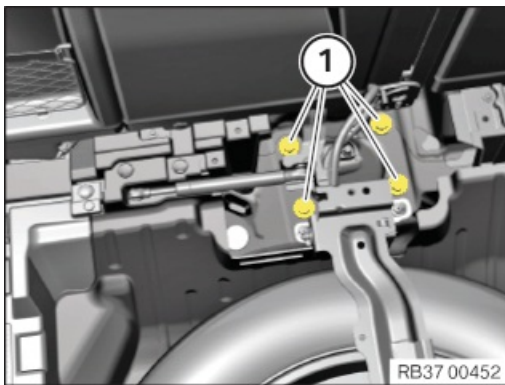

- Position air suspension strut in the wheel arch.
  - Renew screws (1).
- Parts:** Screws
- Tighten the screws (1).

**Rear spring strut/air suspension strut to body**

M10	Renew screw.	Tightening torque	56 Nm
		Angle of rotation	90 °

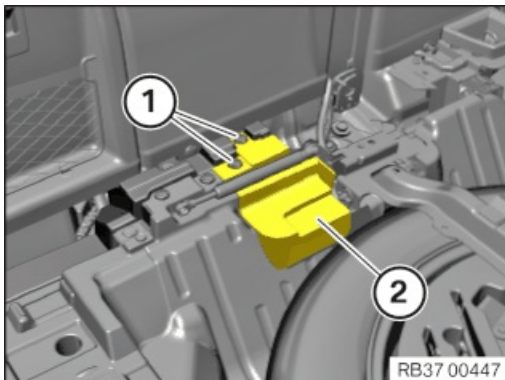

- **If installed:**
- Position cover (2) on the side member.
- Mount the clips (1).

**POSTPROCESSES**

**12-Connecting the connector to spring strut**

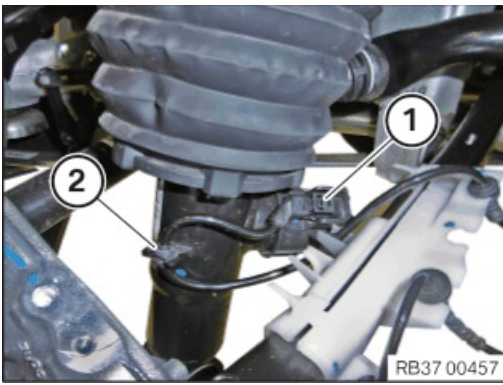

- Attach the cable on the holder (2).
- Connect the connector (1) to the spring strut and lock it.

### 13-Installing the camber control arm

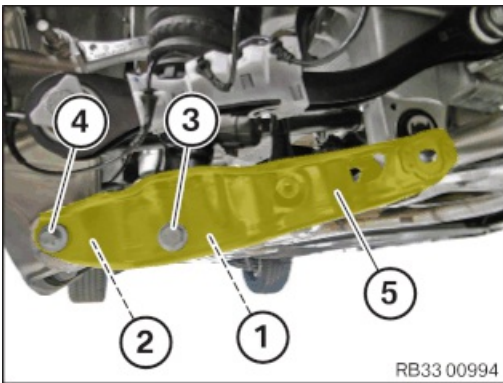

- Position the camber control arm (5).
- Renew screw (4) and nut (2).

**Parts:** Screw

**Parts:** Nut

- Insert screw (4).
- Tighten nut (2).

#### Camber control arm to wheel carrier

M14	Renew screw and nut.	Jointing torque	165 Nm
		Angle of rotation	90 °

#### **i** TECHNICAL INFORMATION

The bolting is tightened with the torque wrench later in normal position.

- Insert screw (3).
- Tighten the nut (1) hand-tight.

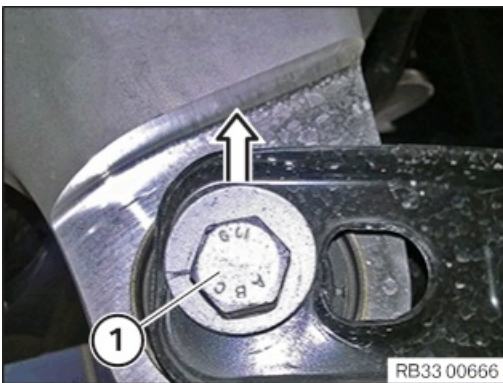

#### **i** TECHNICAL INFORMATION

The vehicle ride height may change as a result of turning the eccentric bolts for the adjustment of toe and camber. When renewing the bolts, make sure the eccentric bolts are correctly positioned to keep the ride height change to a minimum during the adjustment work.

- Position the eccentric bolt (1) during renewal in a way that the eccentric points vertically upwards!

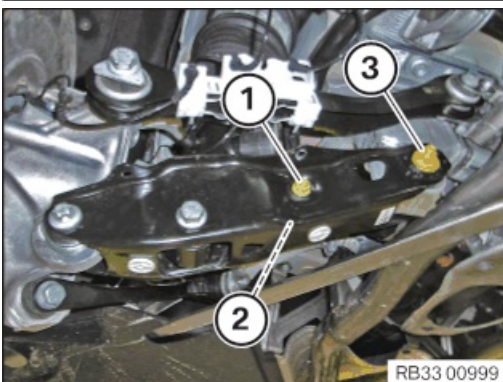

#### **i** TECHNICAL INFORMATION

The bolting is tightened with the torque wrench later in normal position.

- Press the camber control arm upwards and position on the rear axle support.
- Position the anti-roll bar link on the camber control arm.
- Renew the screw (2) and the nut (1).

**Parts:** Screw

**Parts:** Nut

- Insert the screw (2) from front side.
- Tighten the nut (1) hand-tight.
- Renew the eccentric bolt, the eccentric washer and the nut (3).

**Parts:** Eccentric bolt

**Parts:** Eccentric washer

**Parts:** Nut

- Insert the eccentric bolt on the rear axle carrier.
- Position the eccentric washer and hand-tighten the nut (3).

## 14-Installing the rear left wheel

### ► Mounting the wheel

### ► Cleaning the contact surfaces between the brake disc and the wheel rim

[Additional information is available.](#)

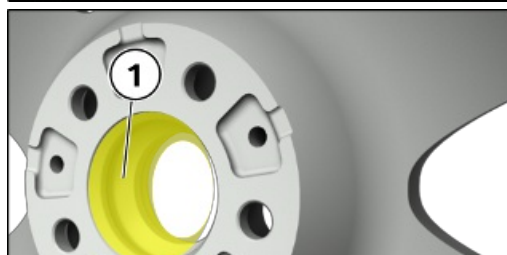
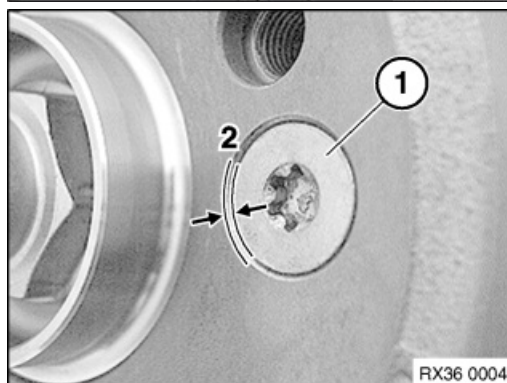
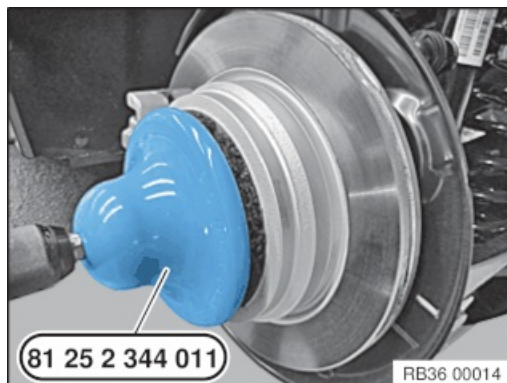

**i TECHNICAL INFORMATION**

The contact surface between the brake disc and the wheel rim must be clean and free from oil and grease. There is otherwise a risk of the wheel becoming loose at a later time.

- Remove dirt, grease residues and corrosion from the contact surface with a drill and the special tool **2 344 011**.  
Do not operate special tool **2 344 011** with an impact screwdriver.
- Degrease the contact surfaces with the universal cleaner (see BMW Group parts sales and distribution).
- If there are grease residues in the area of the wheel bolt holes, remove and clean the brake disc.
- Remove dirt, grease residues and corrosion from the contact surface with a drill and the special tool **2 344 011**.  
Do not operate special tool **2 344 011** with an impact screwdriver.
- Degrease the contact surfaces with the universal cleaner (see BMW Group parts sales and distribution).

- Check that the mounting bolt (1) for the brake disc is securely fitted.

The mounting bolt (1) for the brake disc may **not** protrude on the contact surface (2) between the brake disc and the wheel rim.

#### Brake disc to front wheel hub

M8	Tightening torque	16 Nm
----	-------------------	-------

#### Brake disc to rear wheel hub

M8	Tightening torque	16 Nm
----	-------------------	-------

- Thinly grease the wheel centring (1) in the wheel rim.

#### Expendable materials

Brake pad paste	3g, Bag	83 19 2 158 851
* TU = Trade Unit. TU numbers cannot be ordered! For invoicing purposes only.	100g, Tube	83 19 2 158 852



	5 g, TU*	83 23 0 140 233
--	-------------	-----------------

- Lightly grease the front and rear wheel hubs in this area (1) to protect from corrosion.

**Expendable materials**

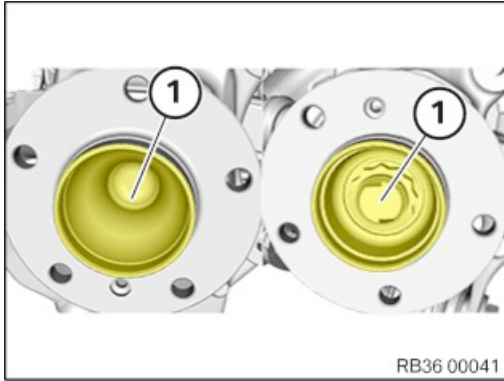

Brake pad paste * TU = Trade Unit. TU numbers cannot be ordered! For invoicing purposes only.	3 g, Bag	83 19 2 158 851
	100 g, Tube	83 19 2 158 852
	5 g, TU*	83 23 0 140 233

<



- In vehicles with carbon ceramic brake: The wheel lift must be used to install the wheel (see workshop equipment).

This process is intended to prevent damage to the brake disc.

**Check**

- Check wheel bolts for wear.

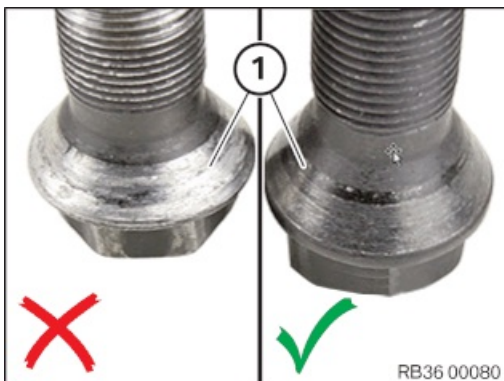

**Result**

» Places (> 30%) of the bearing surface (1) of the taper on the screw head show a silver wear.

**Measure**

- Replace wheel bolts.

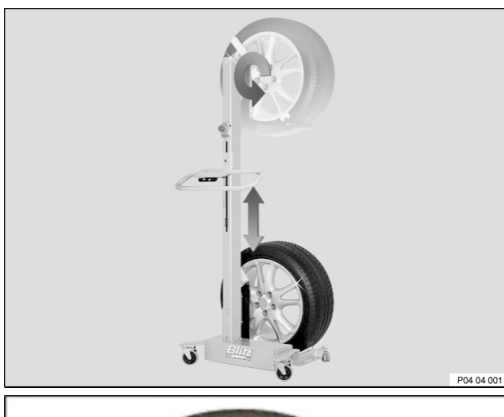

**i TECHNICAL INFORMATION**

A wheel lift is recommended for easier wheel removal and installation without exertion (see Retailer Equipment Catalogue).

- Provide wheel lift.

**i TECHNICAL INFORMATION**

**1 TECHNICAL INFORMATION**



Never use impact screwdrivers or electric screwdrivers to screw in and tighten the wheel bolts.

The wheel rim must rest uniformly against the brake disc.

In the case of non-original BMW wheel bolts/wheel rims, it may be necessary to retighten the wheel bolts on account of setting properties (refer to the documentation from the manufacturer).

Do not apply oil to new wheel bolts.

Recutting a damaged thread (wheel bolt/wheel hub) is not permissible!

- Renew corroded wheel bolts (arrows).
- Clean the wheel bolts (arrows).
- Check the wheel bolts (arrows) and threads for damage, renew the wheel bolts (arrows), if necessary.
- Position and tighten the wheel bolts (arrows).

**Wheel bolts**



M 14/width across flats 17	Screw in wheel bolts and evenly apply crosswise by hand to centre the wheel rim.	Tightening torque	140 Nm
	Tighten wheel bolts crosswise to the specified tightening torque with a calibrated torque wrench.	Check	140 Nm
	Check all wheel bolts in the same order or retighten to the specified tightening torque again.		

**15-If installed: Install the third-row seating (additional work flat rate unit number: 33 52 991)**

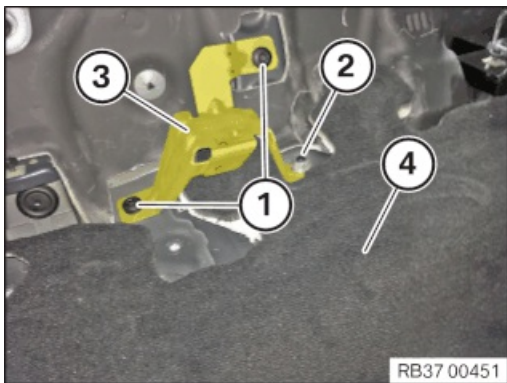

**NOTICE**

Description is for right component only. The procedure on the left side is identical.

- Position the luggage compartment floor trim panel (4).
- Position holder (3).
- Renew the bolts (1) and the nut (2).

**Parts:** Screw

**Parts:** Nut

- Tighten the bolts (1) and the nut (2).

**Bracket to body**



M10	Renew the bolts and the nut.	Tightening torque	42 Nm
-----	------------------------------	-------------------	-------

**► Install 3rd row of seats**

**RISK OF DAMAGE**

**Careless handling of tools and sharp-edged components.**

**Scratch, surface damage.**

- Protect working area.
- Handle tools and components carefully.

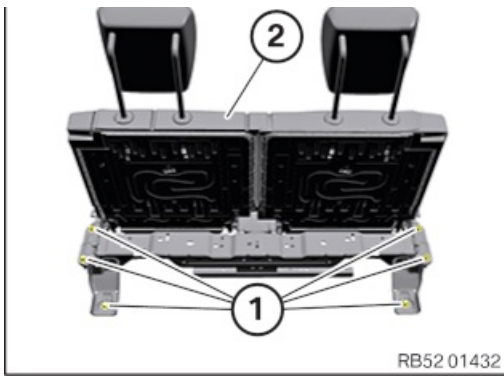

**RISK OF DAMAGE**

**Heavy component.**

Heavy components can lead to injury or damage.

- Remove and install heavy components with the aid of another person/other persons.

- Position the third-row seating (2) with the assistance of an auxiliary person.
- Tighten the screws (1).

**3rd row seats to body**



Screw	Tightening torque
	42 Nm

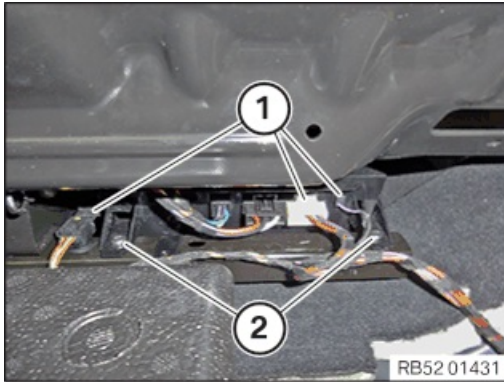

- Connect connectors (1) and lock.

**Note** Plug connections are located on the right underside of the 3rd row of seats and can be reached via the luggage compartment floor trim panel.

- Clip in the cable clip (2).

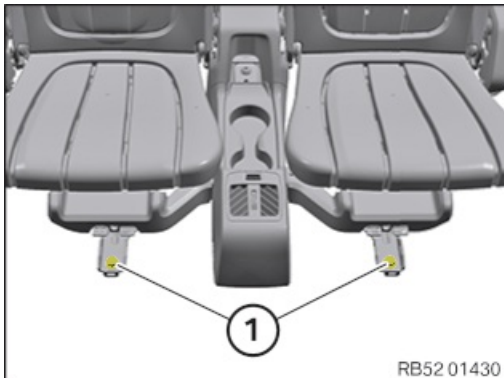

- Tighten the screws (1).

**3rd row seats to body**



Screw	Tightening torque
	42 Nm



- Check marked guide pins for damage. Renew the seat rail cover (1) if necessary.

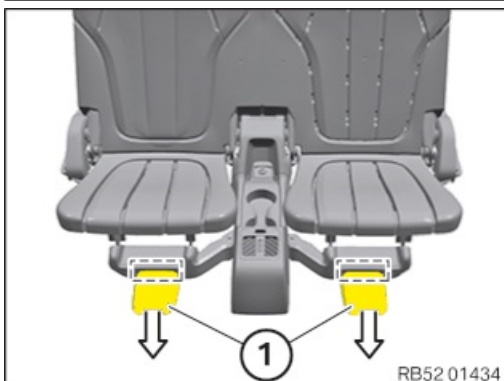

- Position seat rail cover (1) in the marked area and install in direction of arrow.

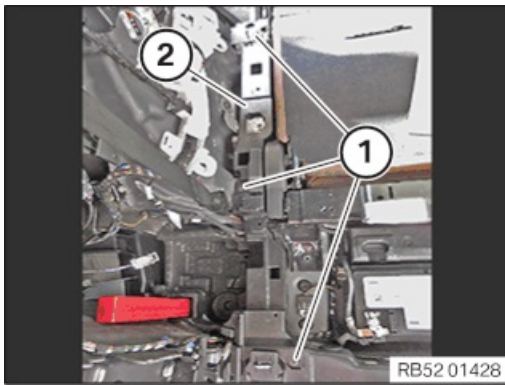

**NOTICE**

Perform the steps on the left and right side.

- Position the cover (2) of the side member.
- Tighten the screws (1).

**Side member cover to bodyshell**

Screw				3 Nm
-------	--	--	--	------

**► Installing the left luggage compartment wheel arch trim panel (with 3rd row of seats)**

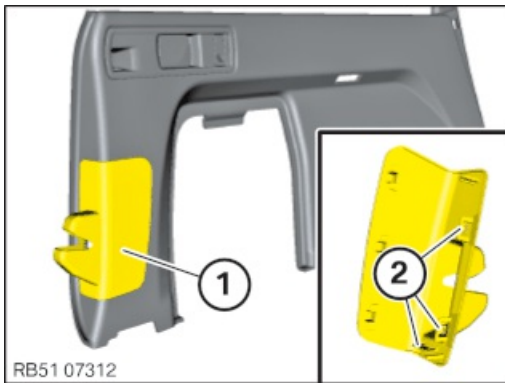

- Release the cover (1) from behind on the catch mechanisms (2) and remove.

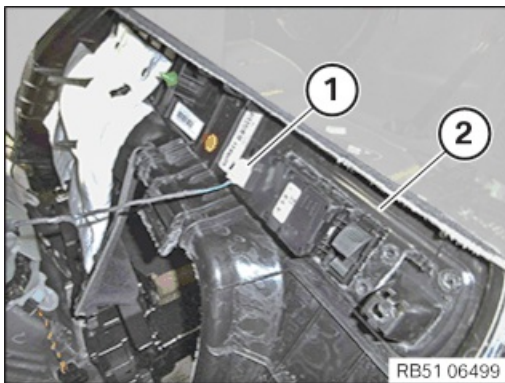

- Insert luggage compartment wheel arch trim panel (2) at the tailgate lock.
- Connect connector (1) and lock.

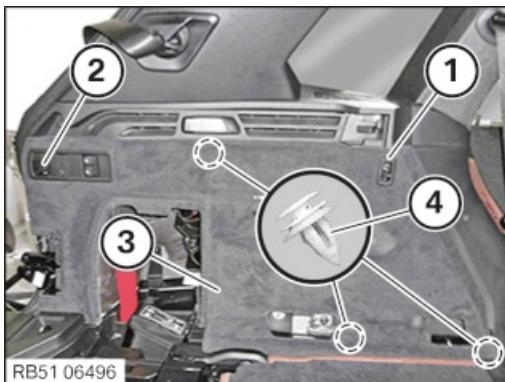

- Position the luggage compartment wheel arch trim panel (3) correctly and clip in at the clips (4).
- Tighten the bolt and install the cover (2).

**Luggage compartment wheel arch trim panel to body**

Screw		Tightening torque	3,0 Nm
-------	--	-------------------	--------

- Tighten screw (1).

**Luggage compartment wheel arch trim panel to body**

Screw		Tightening torque	3,0 Nm
-------	--	-------------------	--------

- Renew the screw (1).

**Parts:** Screw

- Install the end fitting and tighten the screw (1).

**Seat belt end fitting to body (third-row seating)**

Screw	Renew screw.	Tightening torque	42 Nm
-------	--------------	-------------------	-------

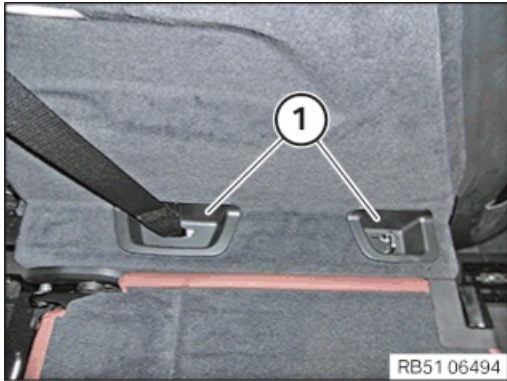
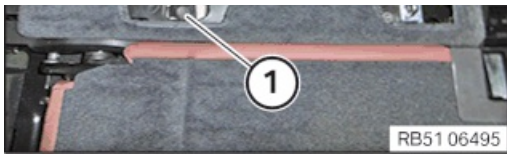

- Feed in and install the covers (1).

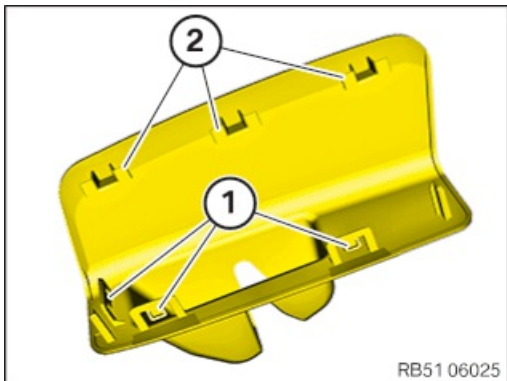

- Check latch mechanisms (1) and guides (2) for damage and that they are present; renew cover if necessary.

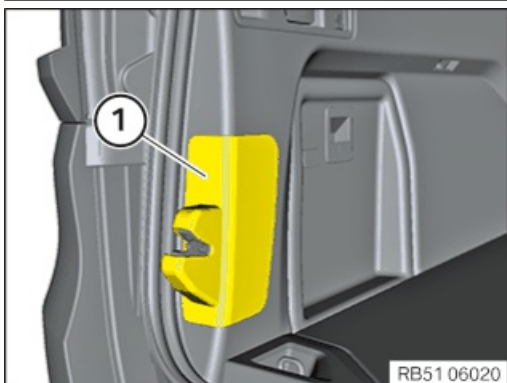

- Install and lock cover (1).



► **Installing the battery cover**

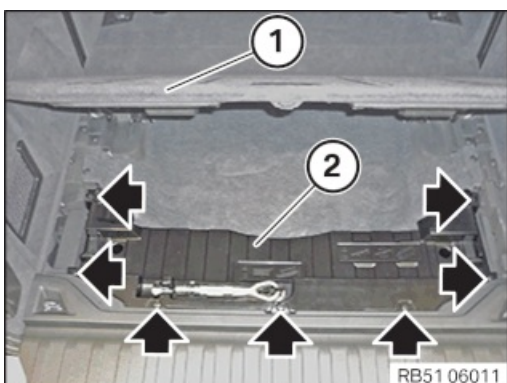

- Correctly position the battery cover (2) and fasten the expanding rivets (arrows).
- Close the luggage compartment floor trim panel (1).



► **Installing loading edge trim**

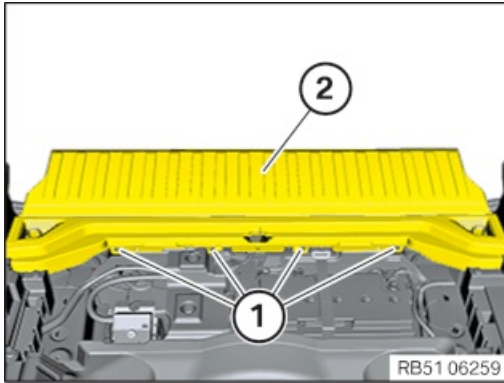

- Guide in loading edge trim (2) and position it correctly.
- Tighten the screws (1).

**Loading edge trim to body**



Screw	Tightening torque	3,0 Nm
-------	-------------------	--------

**16-Installing the luggage compartment floor trim panel**

**i TECHNICAL INFORMATION**

Different versions may be installed depending on the vehicle equipment.

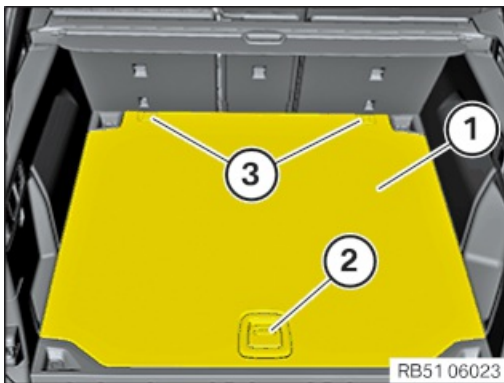

- Install luggage compartment floor trim panel (1), engage it behind the latch mechanisms (3) and lock it to the handle (2).

► **Installing luggage compartment floor trim panel (electrical roller cover for luggage compartment)**

**Prerequisite**

The electrical roller cover for luggage compartment must be at the top. Raise it if necessary.

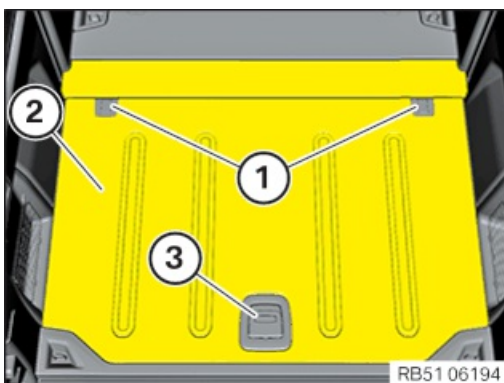

- Guide in luggage compartment floor trim panel (2), position it correctly and lock it on the handle (3).
- Tighten the screws and close covers (1).

**Luggage compartment floor trim panel to holder**



Oval-head screw	Tightening torque	15 Nm
-----------------	-------------------	-------



- Fold up lid (1) and connect and lock connector (2).

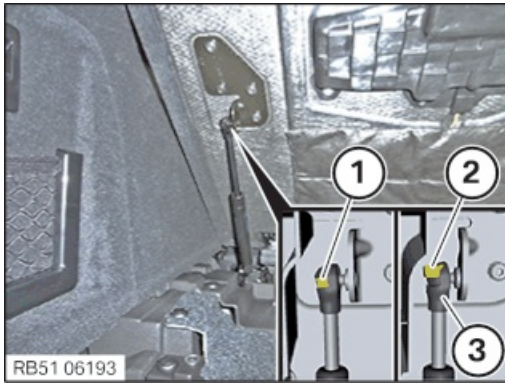

- Raise luggage compartment floor trim.

**NOTICE**

Perform the steps on the left and right side.

- Slide back clamp (1) again from removal position (2).
- Connect and lock gas pressure spring (3) on the ball head.



► **Installing luggage compartment floor trim panel (with 3rd row of seats)**

- Position luggage compartment floor trim panel (2) correctly and lock it on holder (3).
- Tighten the screws and close covers (1).

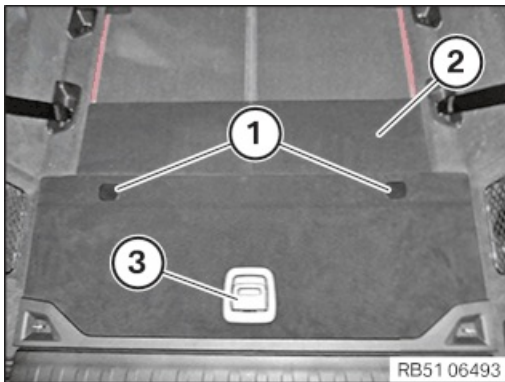

**Luggage compartment floor trim panel to holder**

Oval-head screw	Tightening torque	15 Nm



**17-Activating and filling the air suspension system**

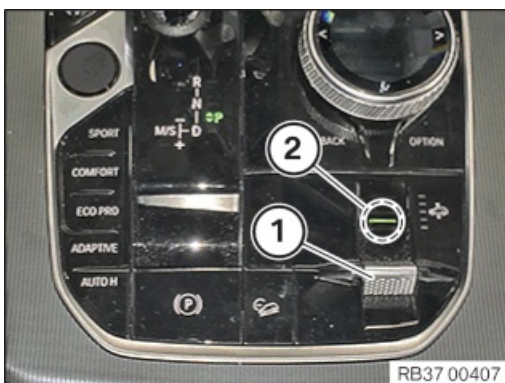

- Switch the ignition on.
  - Press self-levelling suspension button (1) for 7 s and then release it.  
When activated successfully, the indicator light for the air spring system (self-levelling suspension) (2) lights up again.
- Note** Pressing the self-levelling suspension button (1) briefly or longer does not cause the air spring system to activate.
- Set vehicle down on its wheels.
  - Start engine.
- The air spring system is filled automatically.

**18-Measuring the ride height of rear axle and adjusting the normal position**



- Set vehicle on its wheels (for example, workshop pit or vehicle lift for Kinematics Diagnosis System).
- If installed: Deactivate air suspension system.
- Measure the ride height (A).
- Load or unload the vehicle until the ride height (A) is within the tolerance.

**G05t: Four-wheel drive / rear-wheel drive, steel spring**





Measured from centre of wheel hub to lower edge of wheel arch

Dimension A 451+10mm  
-10

#### G18: All-wheel drive, steel spring



Measured from centre of wheel hub to lower edge of wheel arch

Dimension A 451+10mm  
-10

#### G05: Four-wheel drive / rear-wheel drive, air spring



Measured from centre of wheel hub to lower edge of wheel arch

Dimension A 454+10mm  
-10

#### G18: All-wheel drive, Air spring



Measured from centre of wheel hub to lower edge of wheel arch

Dimension A 456+10mm  
-10

#### G06t: Four-wheel drive / rear-wheel drive, steel spring



Measured from centre of wheel hub to lower edge of wheel arch

Dimension A 444+10mm  
-10

#### G06t: Four-wheel drive / rear-wheel drive, air spring



Measured from centre of wheel hub to lower edge of wheel arch

Dimension A 447+10mm  
-10

#### G07t: All-wheel drive, Air spring



Measured from centre of wheel hub to lower edge of wheel arch

Dimension A 461+10mm  
-10

## 19-Tightening the screw connections on the camber control arm

### i TECHNICAL INFORMATION

Tighten the screw connection in the normal position.

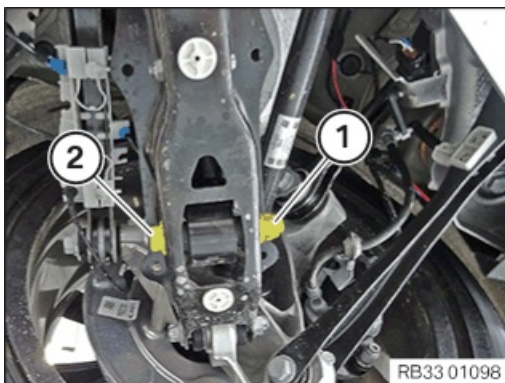

- Loosen nut (1).
- Pull out bolt (2).

### ► Relieving the joint bush in the spring strut/air suspension strut

### i TECHNICAL INFORMATION

In order to prevent losses in drivability, the joint bush from the spring strut or air suspension strut must **strictly** be screwed in the camber control arm free from tension. This is possible only with the following special tool.



- Note that the knurled screw (1) on special tool **2 472 195** always points to the centre of the vehicle.

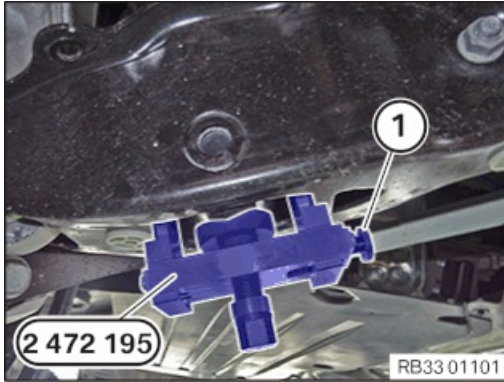

- Feed in and position special tool **2 472 195** on camber arm.
- Hand-tighten knurled screw (1).

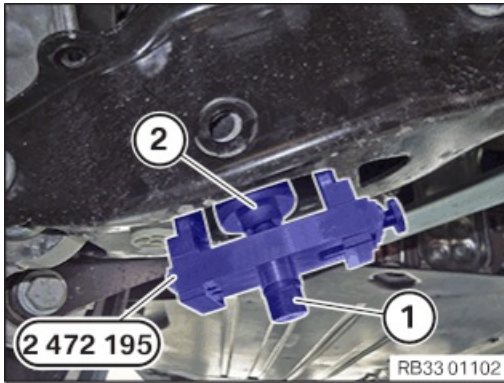

- Align the cam (2) on the special tool **2 472 195** to the joint bush.
- Tighten the spindle (1) to the limit position in direction of arrow hand-tight. The joint bush is detached from the camber control arm and relieved.

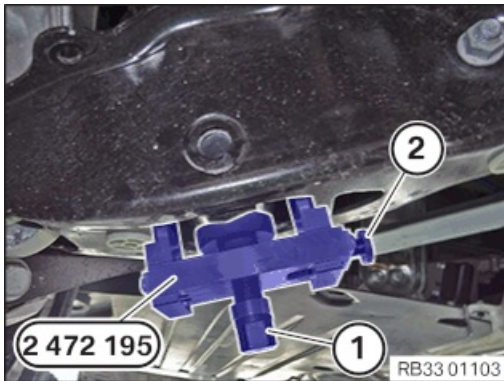

- Detach spindle (1).
- Unscrew the knurled screw (2) and remove the special tool **2 472 195**.

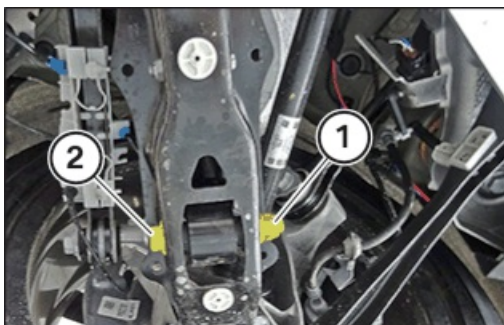

- Renew the screw (2) and the nut (1).

**Parts:** Screw

**Parts:** Nut

- Insert screw (2).
- Tighten nut (1).

**Rear spring strut/air suspension strut to camber control arm**

M14	Renew screw and nut. Tighten in normal position	Tightening torque	165 Nm

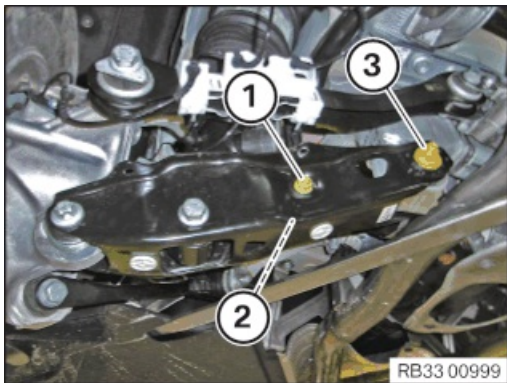

Tighten in normal position.	Angle of rotation	90
-----------------------------	-------------------	----

- Loosen nut (1) by turning it once. In doing so, counter support at the screw (2).
- Tighten nut (1).

**Anti-roll bar link to camber control arm**

M10	Renew screw and nut. Tighten via nut. Tighten in normal position.	Joining torque	56 Nm
		Angle of rotation	180 °

- Loosen nut (3) by turning it once. Counter support on the eccentric screw while doing so.
- Tighten nut (3).

**Tighten the screw connection only after the wheel alignment has been carried out.**

**Camber control arm to rear axle support**

M14	Renew eccentric screw and nut. Tighten in normal position.	Tightening torque	175 Nm
-----	---	-------------------	--------

**20-Installing the cover of the camber control arm**

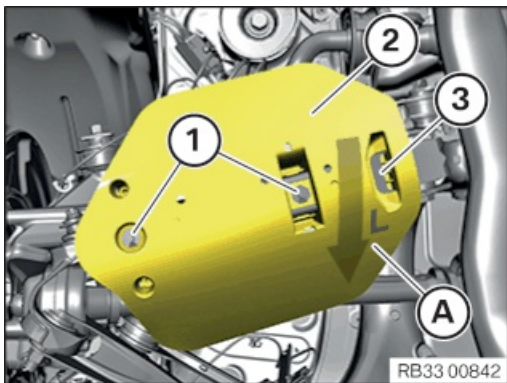

- Feed in and position the cover (2) on the camber control arm (3).

**Note** Note the direction of installation (A). The arrow shows the direction of travel.  
:

- Tighten the screws (1).

**Cover to camber control arm**

Thermoplastic oval-head screw		Tightening torque	3 Nm
-------------------------------	--	-------------------	------