

[BMW G05 X5 sDrive40i SAV](#) / [Repair Manuals and Technical Data](#) / [11 Engine](#) / [11 41 Oil pump with strainer and motor](#) /

## 11 41 000 Removing and installing/replacing oil pump



**Motor vehicle may slip off the vehicle hoist where components are supported.**

**Danger! Life-threatening injuries!**

- Secure the vehicle hoist against lowering and lifting.
- Ensure that the vehicle does not lift off the mounting plates of the vehicle lift.



**Motor vehicle may slip off the vehicle hoist if the weight is distributed unevenly.**

**Danger! Life-threatening injuries!**

- Ensure there is a specific weight compensation on the motor vehicle.



**Vehicle may slip off the vehicle lift if the vehicle lift is handled incorrectly.**

**Danger! Life-threatening injuries!**

- Observe Safety Information on raising the vehicle using a vehicle lift.
- For additional information see: 00 ... Raise the vehicle using a vehicle lift.



**Falling or tipping of a heavy component.**

**Danger! Life-threatening injuries!**

- Before lowering or removing the front axle: Secure the engine in mounting orientation.
- For additional information see: 11 00 670 Securing engine in installation position.



After a brake pad exchange and before actuating the brake pedal: Actuating the electromechanical parking brake is mandatory.

In case of non-compliance, a CC message appears and the brake system switches to the emergency program. The brake power assistance is no longer active.

## PRELIMINARY WORK

### 1 – Bring front compartment lid in the service position

#### Prerequisite

Engine compartment lid is open.



#### Shutting bonnet or tailgate.

#### Danger of injury!

- Support bonnet/tailgate in fully open position with the aid of a suitable device.

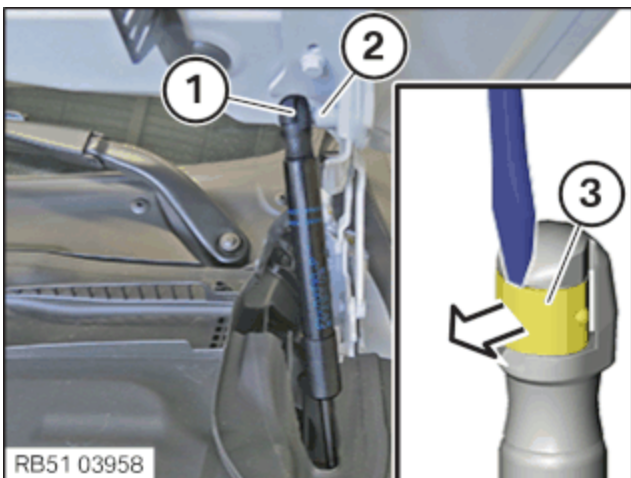

- Lift clamp (3) slightly using a screwdriver, in the direction of the arrow.
- Lift off ball socket (1) from ball pin (2).
- Repeat the operation on the other side of vehicle.

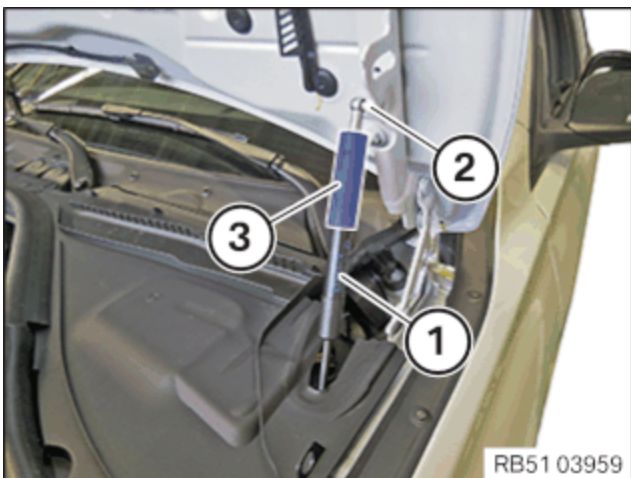

Conduct the following step with the assistance of an auxiliary person.

- Remove the bonnet support and open the bonnet further.
- Pull special tool **0 493 200 (51 2 160)** or (3) over gas pressure spring (1).
- Place special tool on the ball pin (2) and engage using force.
- Repeat the operation on the other side of vehicle.

### 2 – Deactivating the 48V vehicle electrical system

#### Prerequisite

Ignition is switched off.



### Deactivating the 12V vehicle electrical system.

#### Risk of shorting! Risk of fire!

- Make sure that **no battery charger** is connected to the jump start terminal point in the engine compartment.
- For vehicles with additional electrical systems (48V electrical system, high-voltage vehicle electrical system), it is mandatory to deactivate them **before** disconnecting the vehicle battery.



### Deactivate the 48V vehicle electrical system.

#### Risk of shorting! Risk of fire!

- Make sure that **no battery charger** is connected to the jump start terminal point in the engine compartment.



### Damage to 48V battery

**If a 48V battery that is disconnected from the electrical system is activated, the battery electronics will be damaged.**

- Only carry out activation of the 48V vehicle electrical system with a completely connected 48V battery.



Follow notices for 48V battery. See further information 6120 ... Notices on 48V battery.



- Deactivate the 48V vehicle electrical system by opening the bonnet.

The deactivation takes place automatically.

**Check****i**

Voltage free (48V vehicle electrical system is switched off) is displayed only in PAD mode.

- Press the START-STOP button quickly 3 times without stepping on the brake pedal to establish the PAD mode.
- Check that the instrument cluster (KOMBI) is voltage free in PAD mode.

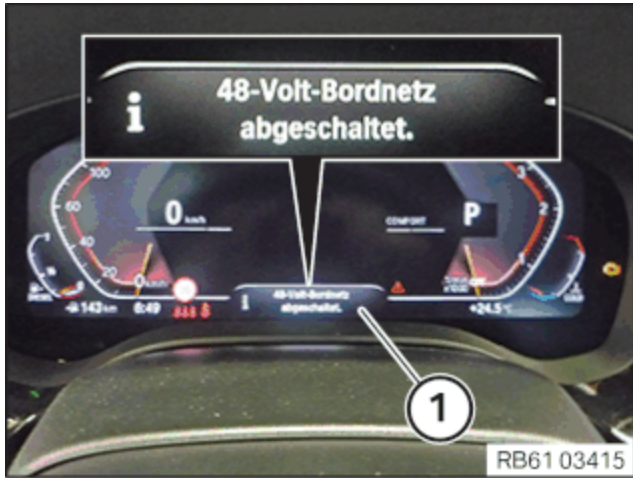

**desired state**

- The Check Control message "48V electrical system switched off." (1) is displayed.

**Result**

- » **The voltage free state** cannot be determined by means of the Check Control message "48V electrical system switched off." (1) . Starting work is not permitted.

**Measure**

- Carry out the service function "48V electrical system deactivation".
  - Vehicle management > Service functions > Voltage supply > Deactivate 48V electrical system

Only when the Check Control message "48V electrical system switched off." (1) is displayed in the instrument cluster (KOMBI) is it permitted to disconnect the 12V battery.

**Result**

- » **The voltage free state** cannot be determined by means of the Check Control message "48V vehicle electrical system switched off" or "additional electrical storage switched off." (1) . **Starting work is not permitted.**

**Measure**

- See additional information:

Isolate additional storage with fault memory entry relay sticking closed from power supply

**Result**

- » The Check Control message signals that the 48V vehicle electrical system has been turned off.

**Measure**

- Exit PAD mode by pressing the START-STOP button once without actuating the brake pedal.

The work "Disconnecting the negative battery cable of the 48V battery" can be started.

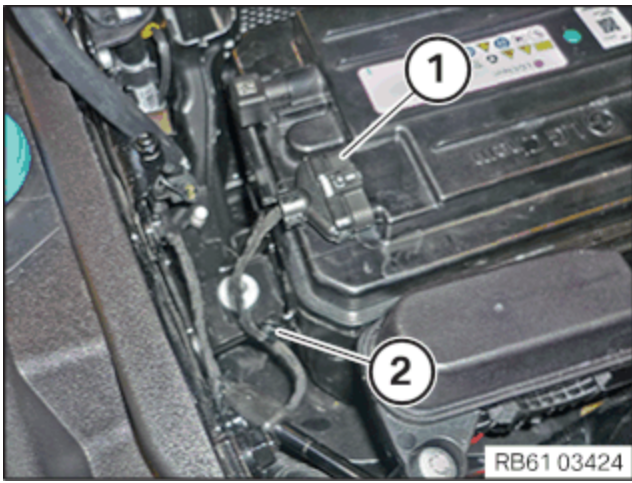

- Unlock and disconnect plug connection (1) of the CAN bus.
- Release the clip (2).

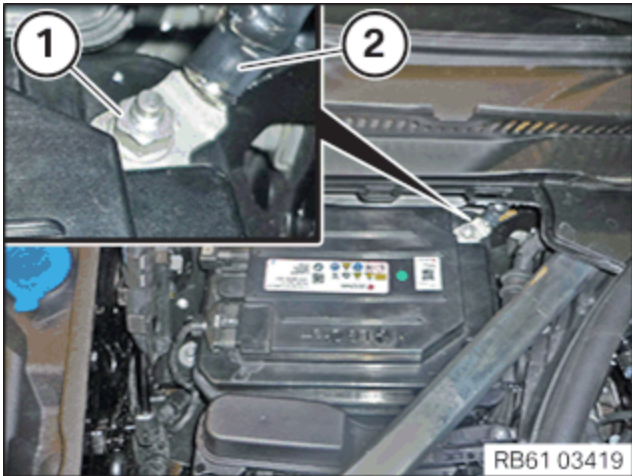

- Loosen nut (1).
- Pull off negative battery cable (2) of the 48V battery from the negative battery terminal, set it aside and secure it.

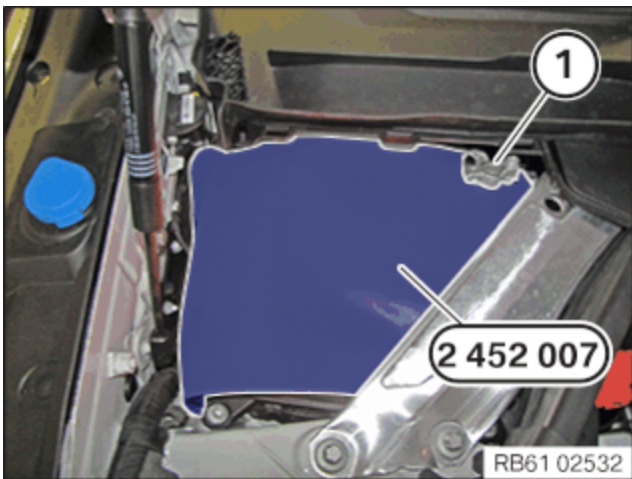

**Unprotected battery terminals.**

**Risk of shorting! Risk of fire!**

- Cover the battery.
- Cover the vehicle battery with the special tool as shown.
- Position the negative battery cable (1) as shown.

### 3 – Deactivate vehicle-specific high-voltage or low-voltage vehicle electrical system



**Damage to the high-voltage battery due to insufficient deactivation of the high-voltage system before disconnecting the vehicle battery via Service Disconnect in BEV and PHEV vehicles.**

#### Damage to the high-voltage system!

- It is **essential to deactivate the high-voltage system before disconnecting** the vehicle battery via Service Disconnect on BEV and PHEV vehicles.
- All work on the high-voltage system may only be carried out by specially trained and technically experienced personnel.
- For additional information see:
- For additional information see:



It is mandatory to follow the vehicle-specific instructions given in the **further information!**

- Deactivate the electrical system in accordance with the specifications described in the additional information.

## 4 – Removing the acoustic cover



**Hot surfaces.**

**Risk of burning!**

- Perform all work only on components that have cooled down.



**Damage to the acoustic cover/design cover.**

**Jerky movements during disassembly and excessive application of force during installation may result in breakage of the acoustic cover/design cover.**

- Disassemble or mount the acoustic cover/design cover carefully.
- Disassemble or mount snap-lock couplings of the taper spigots one after the other.
- Disassemble or mount acoustic cover/design cover only at temperatures > 20°C.
- Use only distilled water as an auxiliary material during installation, no lubricating materials.

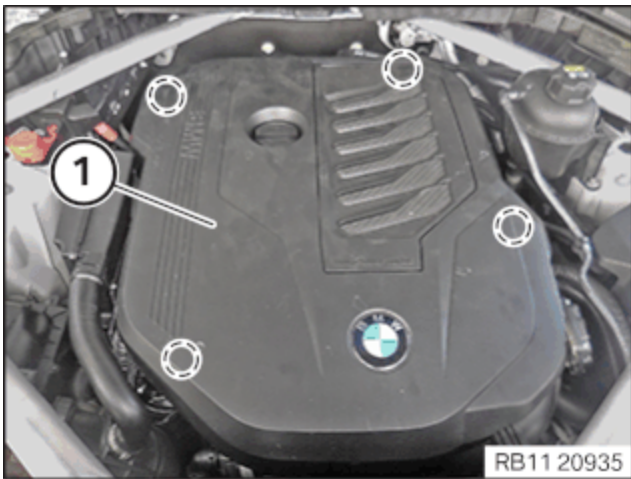

- Release the acoustic cover (1) towards the top from the rubber mounts (marks).

## 5 – Remove the seal for the bonnet in front

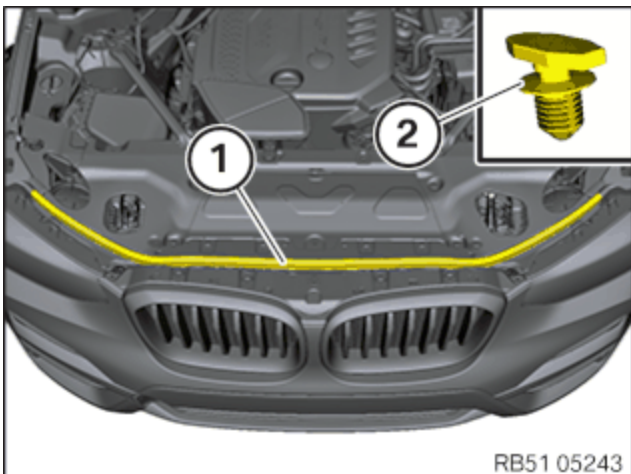

- Unclip and remove front bonnet seal (1) upwards from clips (2) with special tool **2 298 505**.

## 6 – Removing the top right and left cover in the engine compartment

### ► Removing the cover in the engine compartment on top

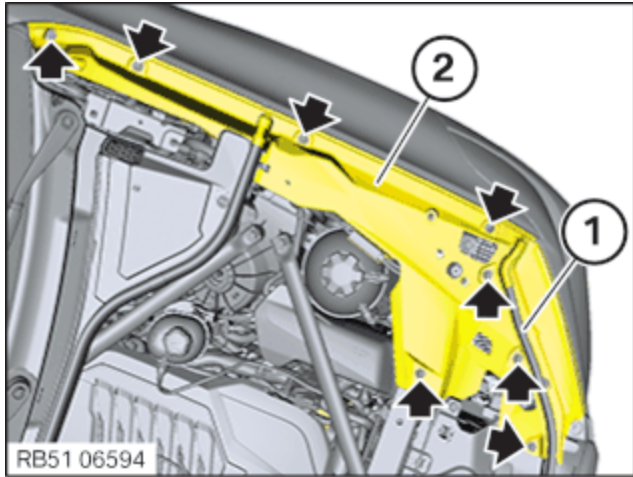

- Release the seal for the bonnet (1) in the area of the cover (2) at the clips with the special tool **2 298 505**.
- Release the expanding rivets (arrows).
- Guide out and remove the cover (2).

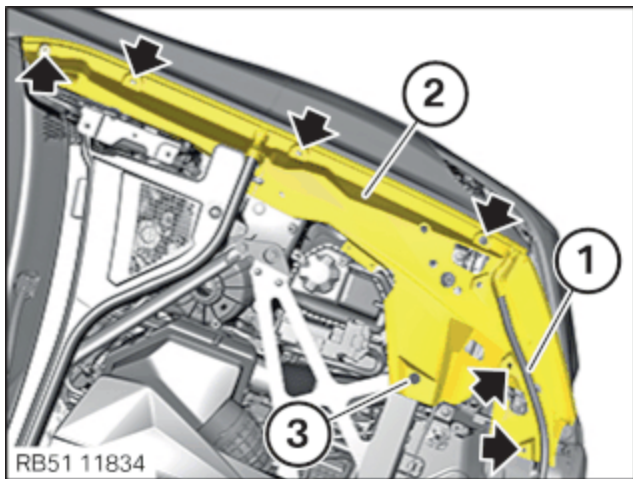

- **Only for F95/F96 LCI vehicles:**
- Release the seal for the bonnet (1) in the area of the cover (2) at the clips with the special tool **2 298 505**.
- Release the expanding rivets (arrows).
- Loosen screw (3).
- Guide out and remove the cover (2).

### ► Remove the top right cover in the engine compartment

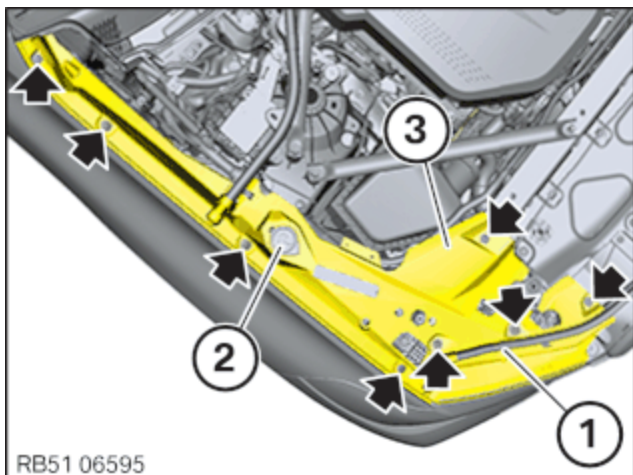

- Release the seal for the bonnet (1) in the area of the cover (3) at the clips with the special tool **2 298 505**.
- Release the expanding rivets (arrows).
- Open and remove lid (2) of washer fluid reservoir.
- Guide out and remove the cover (3).

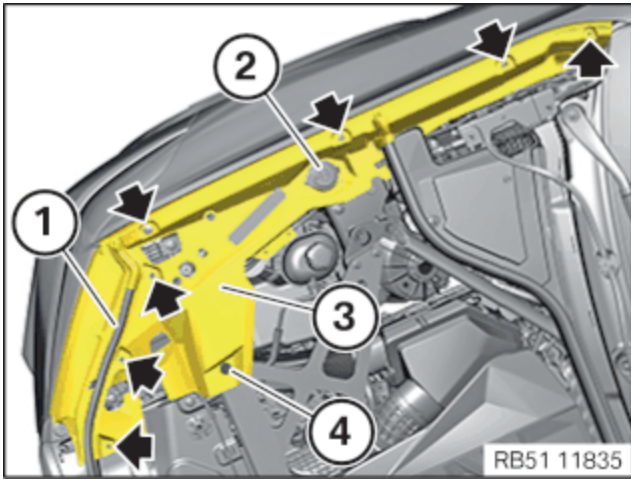

- **Only for F95/F96 LCI vehicles:**
- Release the seal for the bonnet (1) in the area of the cover (3) at the clips with the special tool **2 298 505**.
- Release the expanding rivets (arrows).
- Open and remove lid (2) of washer fluid reservoir.
- Loosen screw (4).
- Pull the cover (3) out and remove it.

## 7 – Removing the oil filler cap

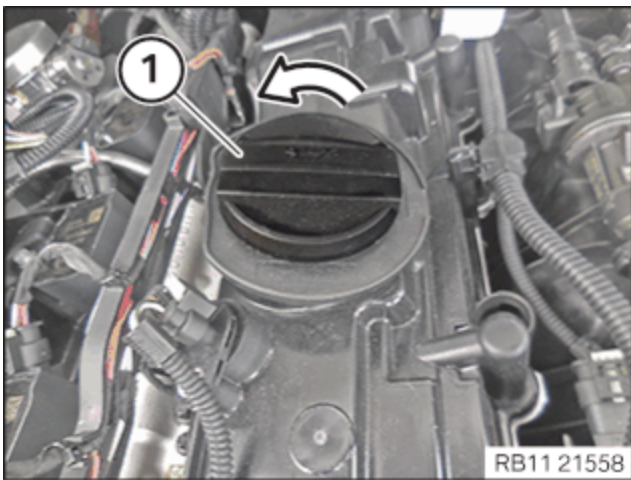

- Open oil filler cap (1) in the direction of the arrow.

## 8 – Removing the front left and right wheels



Perform the steps on the left and right side.

### ► Removing the wheel



P04 04 001



A wheel lift is recommended for easier wheel removal and installation without exertion (see Retailer Equipment Catalogue).

- Provide wheel lift.



RB36 00039

- If several wheels are removed simultaneously: Use a piece of chalk to mark on each tyre the axle and side on which the corresponding wheel is fitted.
- Loosen the wheel bolts (arrows) crosswise and remove the wheel.

Use the matching adapter from tool set (wheel bolt adapter set) to loosen and tighten the wheel bolt with security code.

## 9 – Remove the cover of the steering assembly on the left and right



Perform the steps on the left and right side.

### ► Remove the cover of the steering assembly



To provide a better overview: Schematic diagram with partially hidden components.

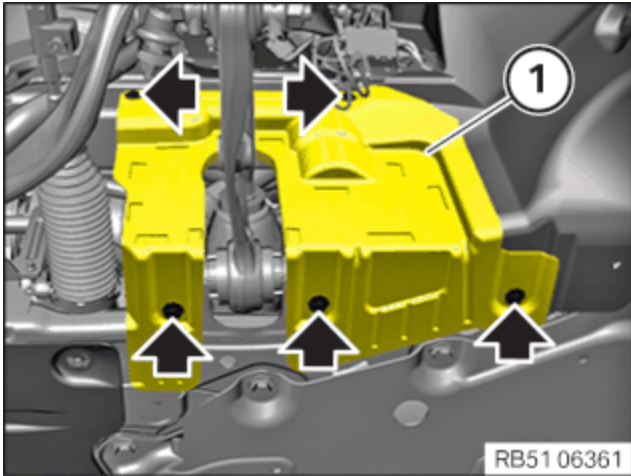

- Release all bolts (arrows).
- Remove cover (1).

## 10 – Partially removing wheel arch trim at the front side sill left and right



Perform the steps on the left and right side.

### ► Partially remove front wheel arch trim on side sill

- **G05/G18/F95:**  
Release wheel arch trim (1) from clips (2).

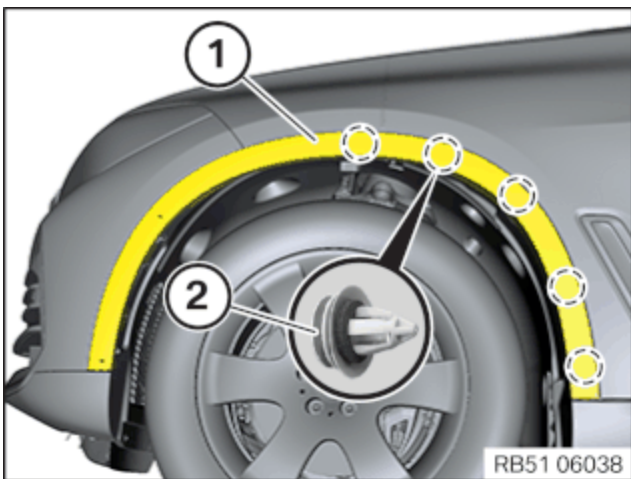

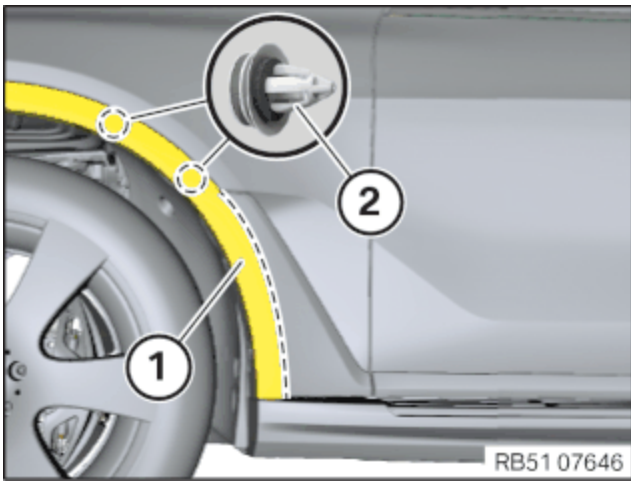

- **G06/G07:**

Release wheel arch trim (1) from the latch mechanisms in the area of the dotted line.

Release wheel arch trim (1) from clips (2).

## 11 – Remove the rear section of the wheel arch cover on the front left and right



Description is for left component only. Procedure on the right side is identical.

### ► Removing the rear section of the front wheel arch cover



To provide a better overview: Schematic diagram with partially hidden components.

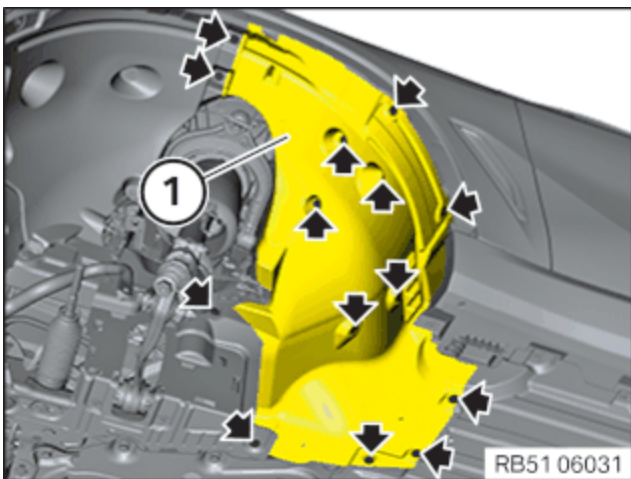

- Loosen screws (arrows).
- Guide out and remove the rear section (1) of the wheel arch cover.

## 12 – Removing the front underbody protection



Different versions may be installed depending on the vehicle equipment.

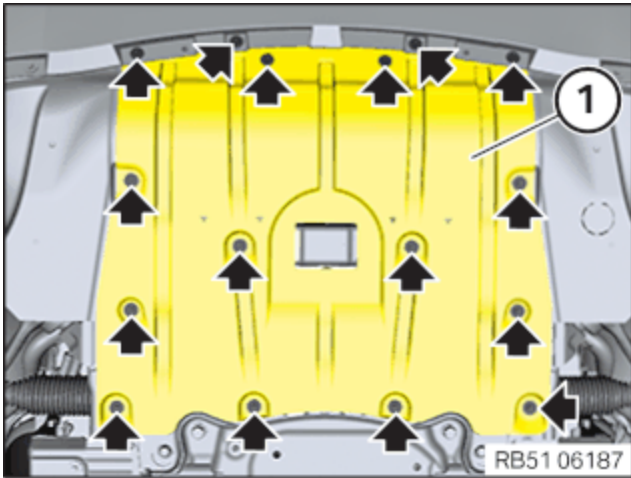

- Remove screws (arrows).
- Guide out front underbody protection (1) and remove it.

### ► Removing the front underride protection



The following step(s) is/are to be carried out if the specified component(s) is/are fitted.

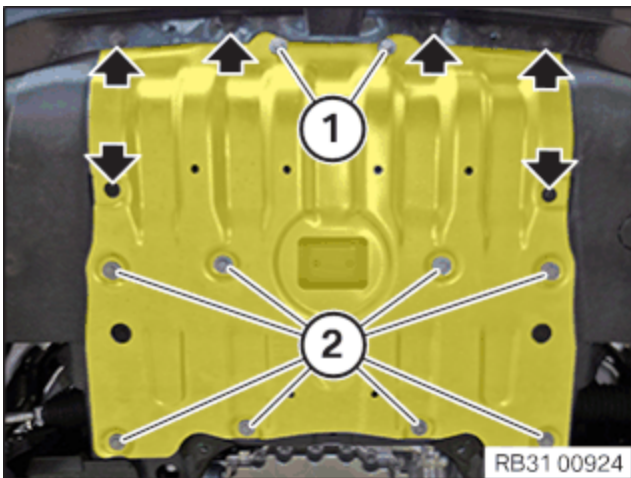

Secure component against falling.

- Remove screws (arrows).
- Loosen screws (1) and (2).
- Feed out and remove the front underride protection.

### 13 – Removing the stiffening plate



Secure component against falling.



Driving without stiffening plate is not permissible.

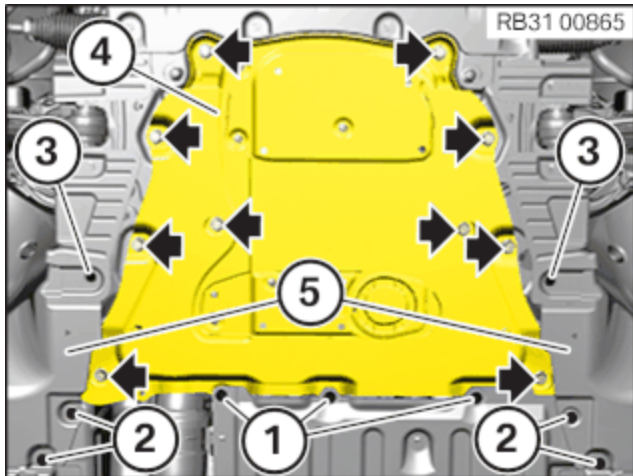

- Loosen screws (1) to (3).
- Remove screws (arrows).
- Feed out the stiffening plate (4) in the area (5) of the wheel arch trim panel and remove.

### 14 – Remove rear underbody protection

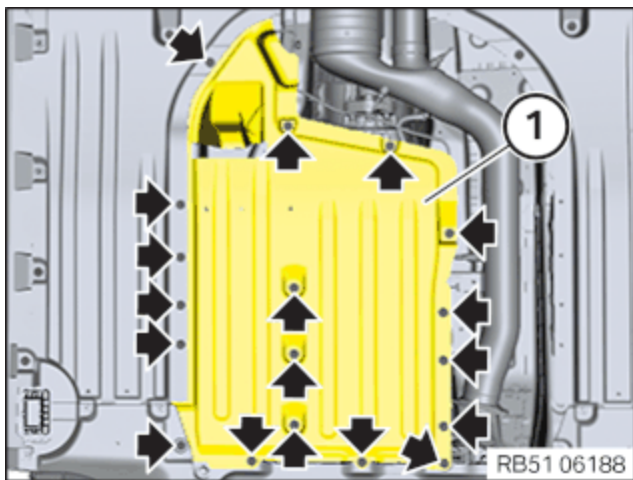

- Remove screws (arrows).
- Guide out underbody protection (1) and remove it.

### 15 – Removing the front lower wheel arch cover on the left and right



Perform the steps on the left and right side.

### ► Removing the front lower wheel arch cover

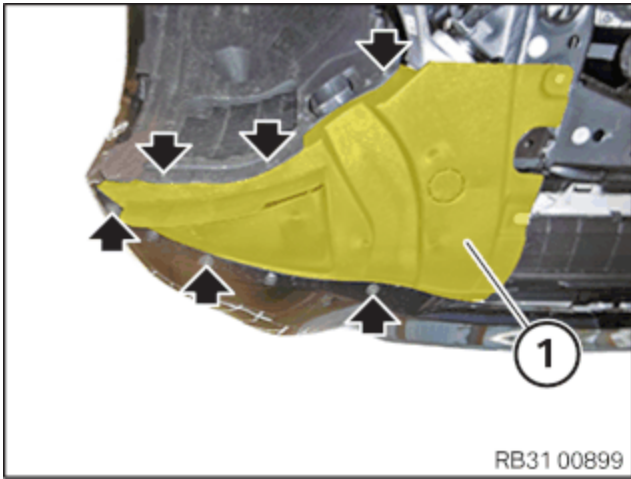

- Remove screws (arrows).
- Guide out the lower section of front wheel arch cover (1).

## 16 – Releasing the oil drain plug



**Hot fluids.**

**Risk of scalding!**

- Conduct all work on the vehicle with appropriate personal protective equipment only.



Catch and dispose of drained engine oil in a suitable collecting vessel. Observe country-specific waste disposal regulations.

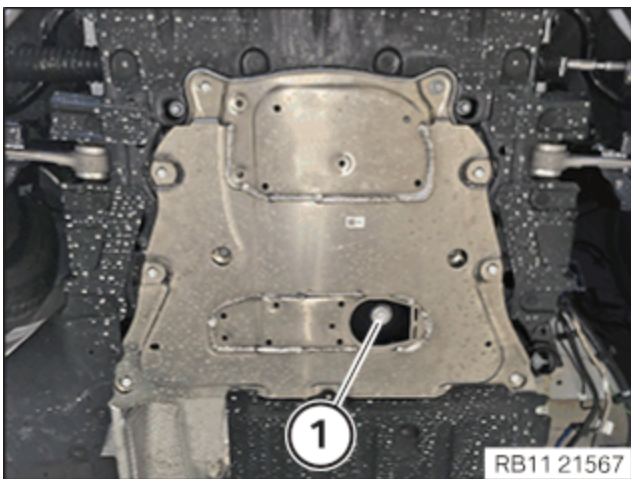

- Release oil drain plug (1).
- Allow the engine oil to drain out fully.

## 17 – Tightening the oil drain plug

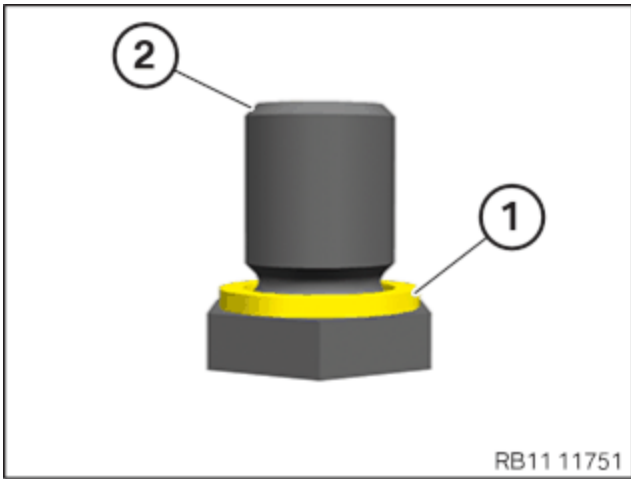

- Renew sealing ring (1) on the oil drain plug (2).
- Parts:** Sealing ring
- Guide in the sealing ring (1) on the oil drain plug (2) and install.

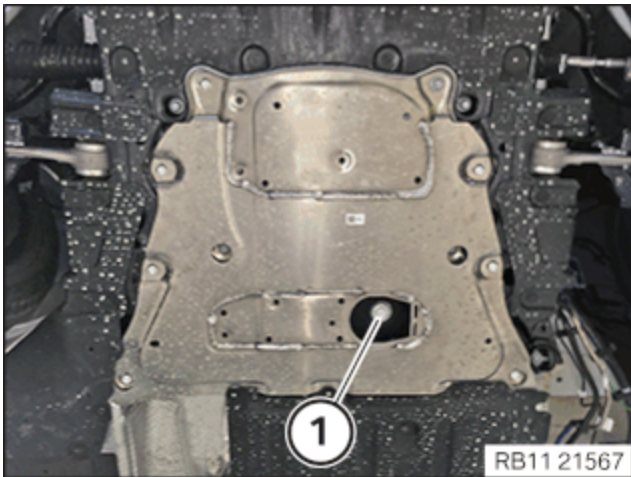

- Guide in oil drain plug (1) and install.
- Tighten oil drain plug (1).

### Oil drain plug

M12x16	Renew the sealing ring.	Tightening torque	25 Nm
--------	-------------------------	-------------------	-------

## 18 – Remove reinforcement brace on right

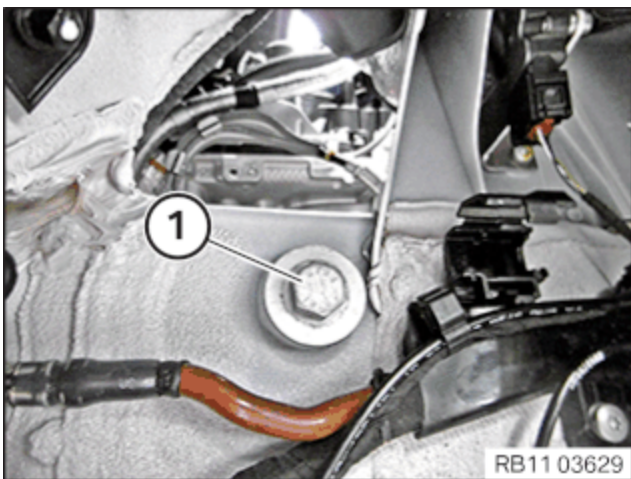

- Loosen screw (1).

- Loosen screw (1).
- Remove the bracing strut (2).

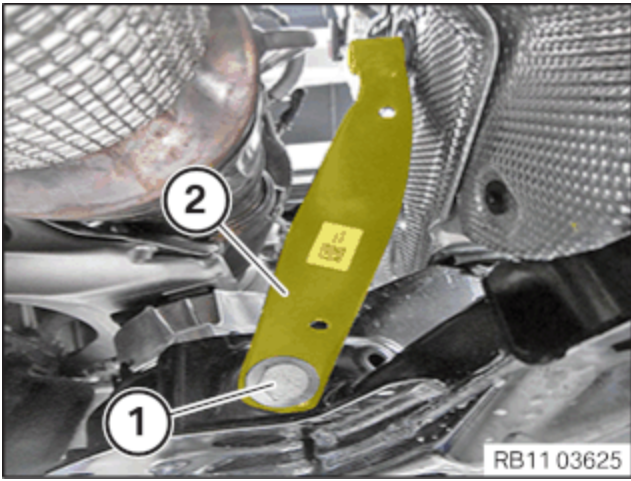

### 19 – Move the engine to the mounting orientation

Prepared engine bridge

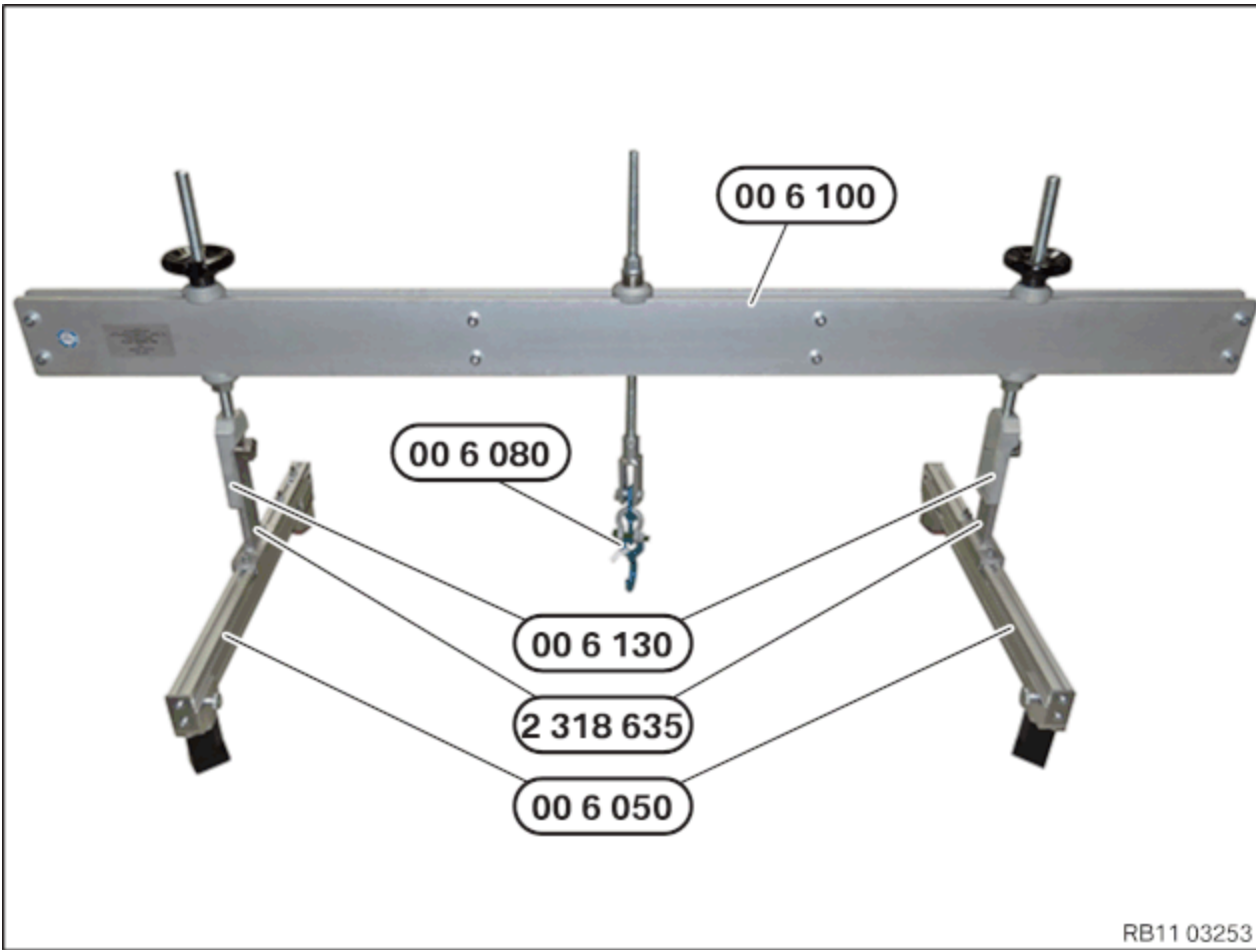

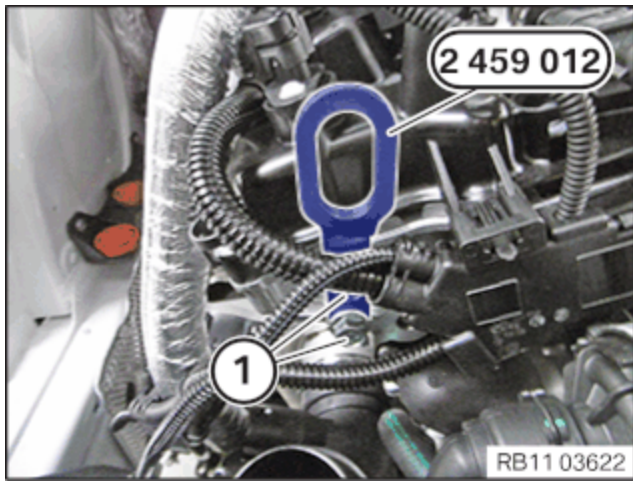

- Guide in and position special tool **2 459 012** on cylinder head.
- Tighten the screws (1) of special tool **2 459 012**.

#### Special tool to cylinder head

M8	Tightening torque	21,5 Nm
----	-------------------	---------



Schematic diagram is for example purposes. Some parts may differ in certain details.



Conduct the following step with the assistance of an auxiliary person.

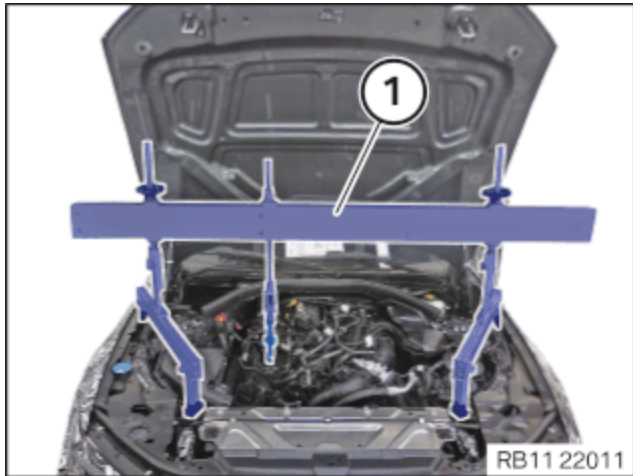

- **Carefully** position engine bridge (1) with help from an auxiliary person.
- Mount rest and the adapter on the profile strip .

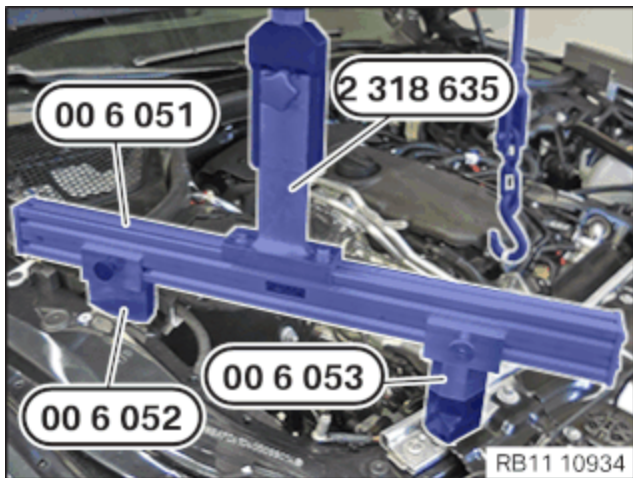

- Position special tool between the screws (1) on the connecting support.

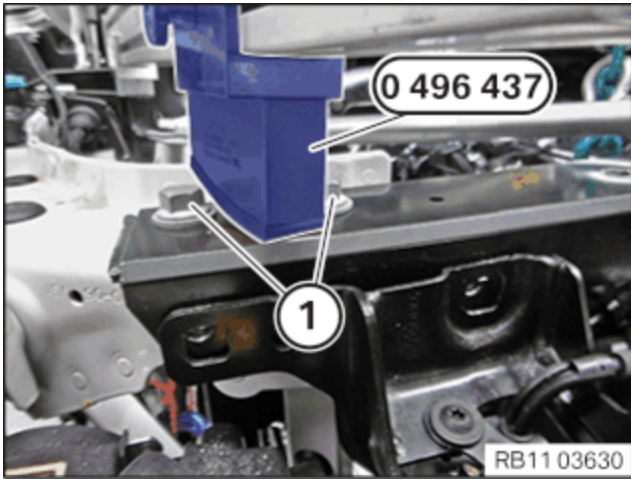

- When positioning the special tools between strut brace and tension strut, make sure that the brake line (1) is not damaged.

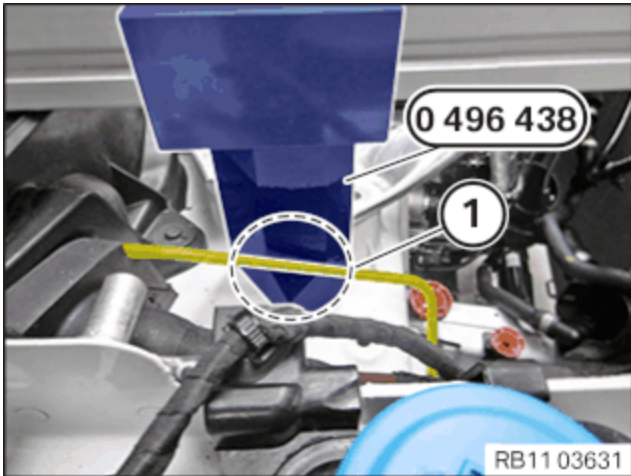

Conduct the following step with the assistance of an auxiliary person.

- Carefully position engine bridge (1) with help from an auxiliary person.
- Position special tools and correctly.



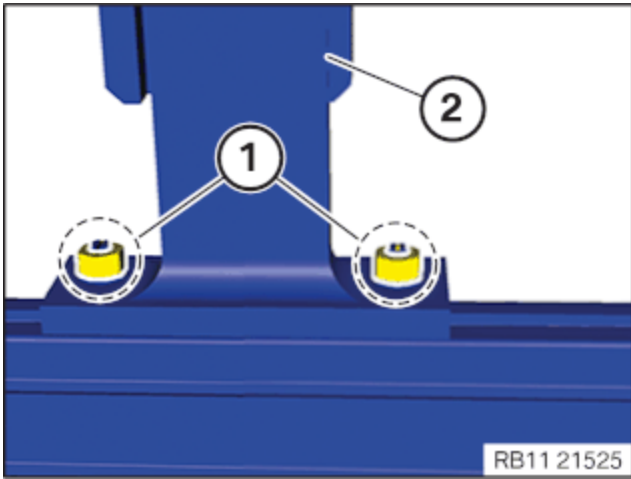

- If necessary, release the nuts (1) and position the engine bridge (2).

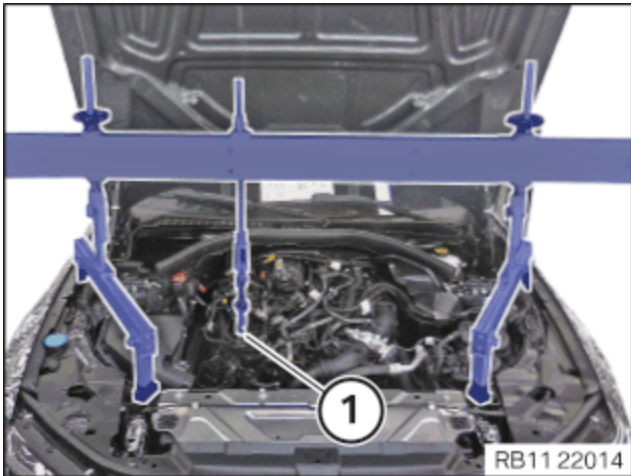

- Align the engine bridge by moving it on the profile strips of the special tool above the engine mounting bracket (1) and screw it down.
- Align the hook above the engine mounting bracket (1).
- Connect the hook to the engine mounting bracket (1).

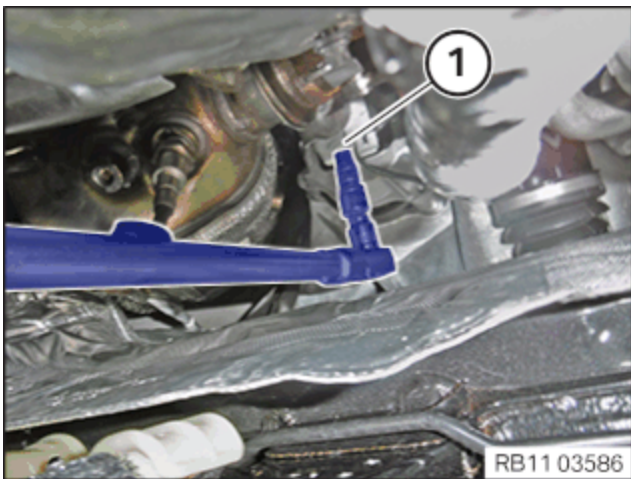

- Release screw (1) on the right engine mount from the top with a commercially available tool.

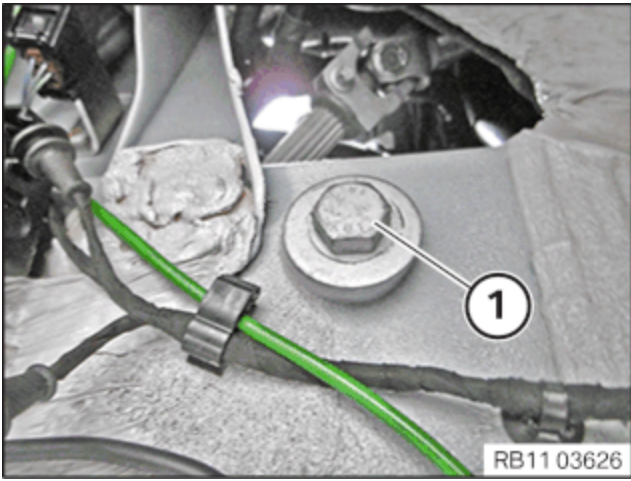

- Loosen screw (1).

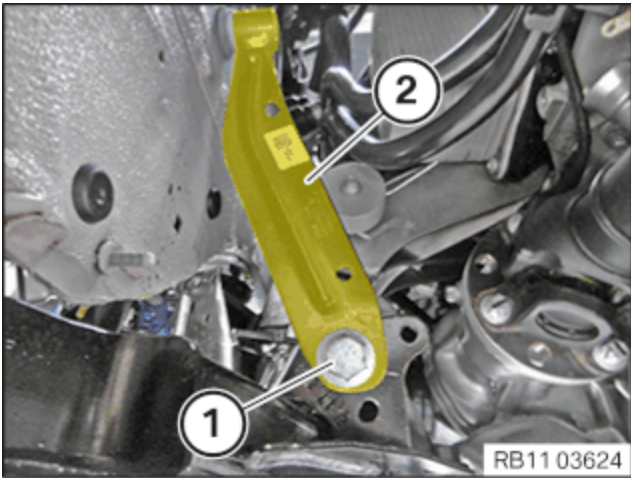

- Loosen screw (1).
- Remove the left bracing strut (2).

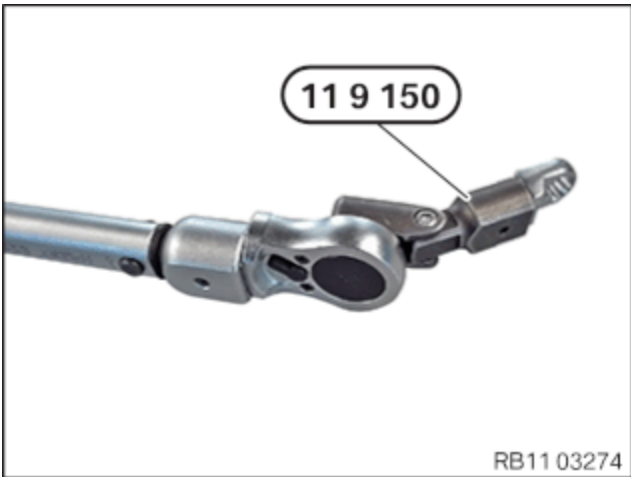

- Prepare special tool **0 493 751 (11 9 150)** as shown.

- Release the screw on the left engine mount from the bottom with special tool **0 493 751 (11 9 150)**.

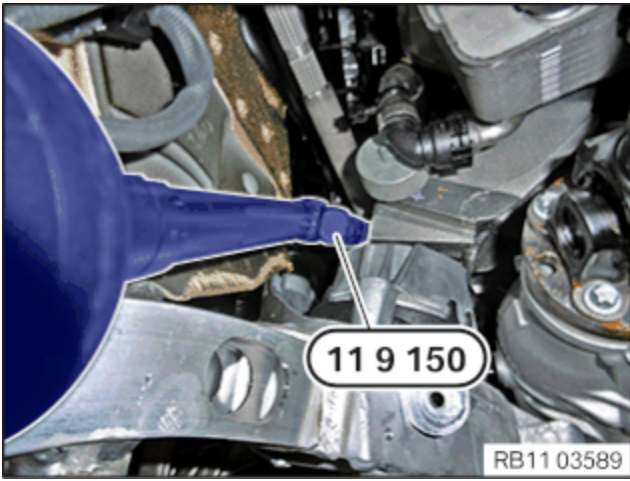

- Raise the engine by turning the spindle **2 361 506 (00 6 103)** by 10 mm.

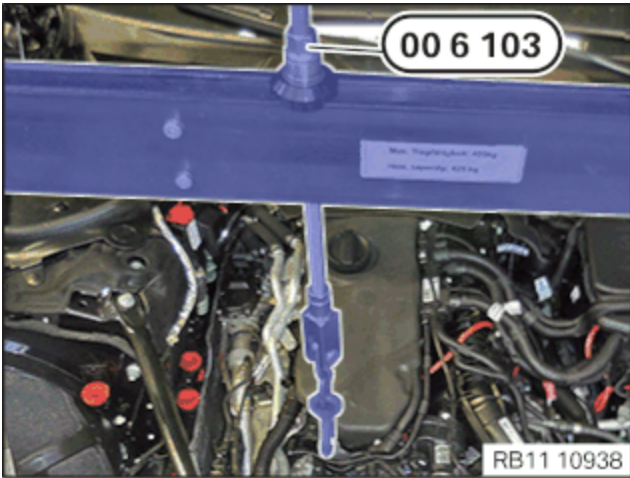

## 20 – Remove left and right crash lever



Perform the steps on the left and right side.

### ► Removing the crash lever



The following step(s) is/are to be carried out if the specified component(s) is/are fitted.

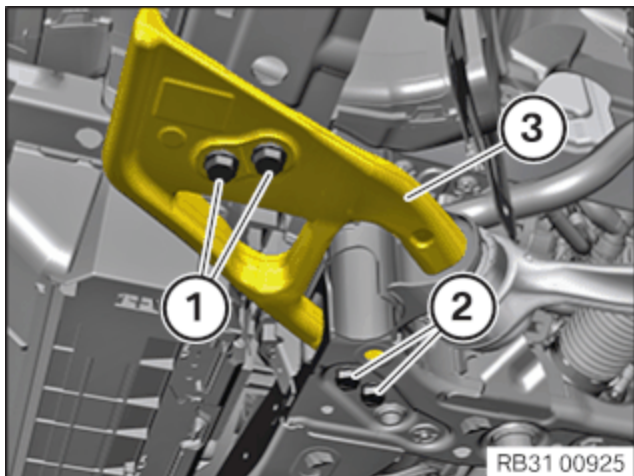

- Loosen screws (1) and (2).
- Remove the crash lever (3).

## 21 – Removing left and right brake air duct



Perform the steps on the left and right side.

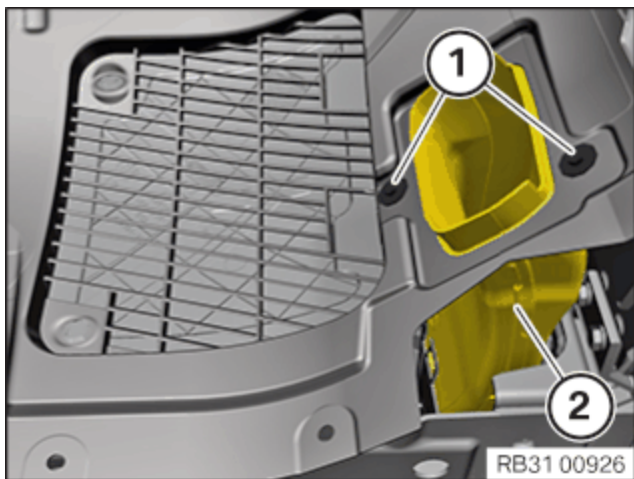

### ► Remove the brake air duct

- Loosen screws (1).
- Guide the brake air duct (2) out and remove.

## 22 – If installed: Release independent heater (additional work flat unit rate number: 31 11 905)

### ► Remove the front section of the front wheel arch cover



To provide a better overview: Schematic diagram with partially hidden components.

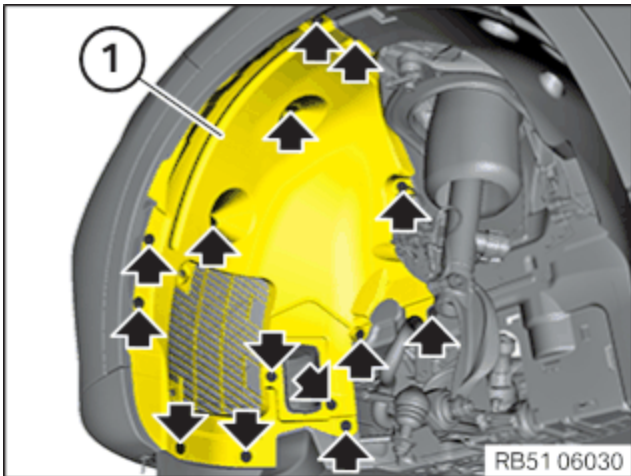

- Remove screws (arrows).
- Guide out the front section of wheel arch cover (1) and remove it.

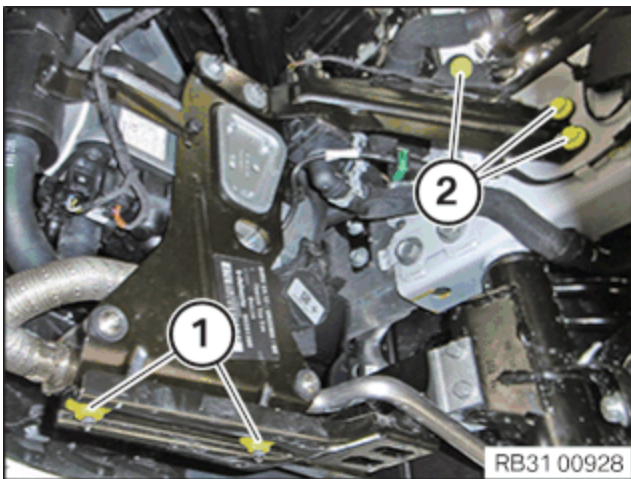

- Loosen nuts (1).
- Loosen screws (2).

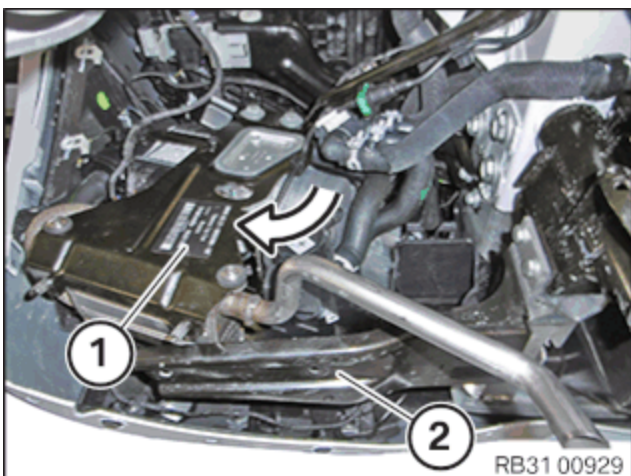

- Release stationary heating system (1) from the holder (2).
- Place the stationary heating system (1) in the direction of arrow to one side.

## 23 – Releasing the wiring harness of the EPS

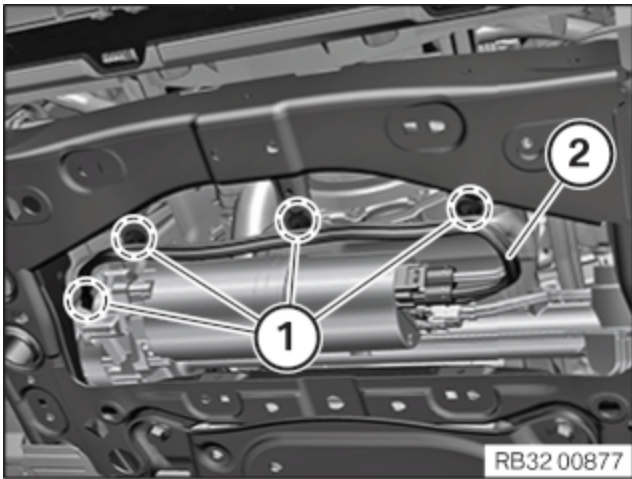

- Release the vehicle wiring harness (2) from the brackets (1).

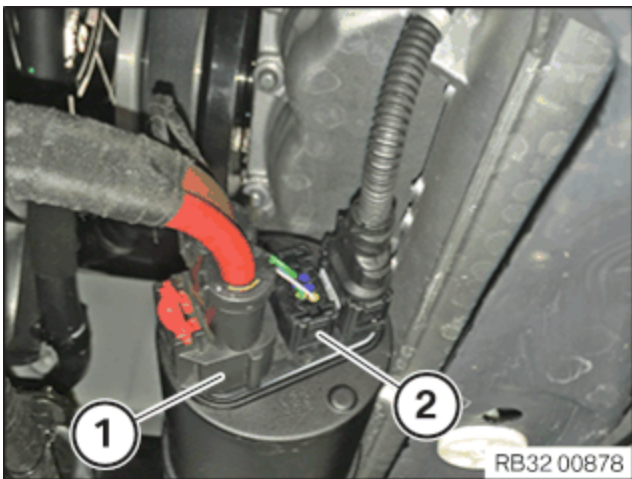

- Unlock and disconnect the plug connections (1) and (2).
- Place wiring harness to one side.

## 24 – Release the wiring harness from the active anti-roll bar (additional work FRU no.: 37 11 999)



The following step(s) is/are to be carried out if the specified component(s) is/are fitted.

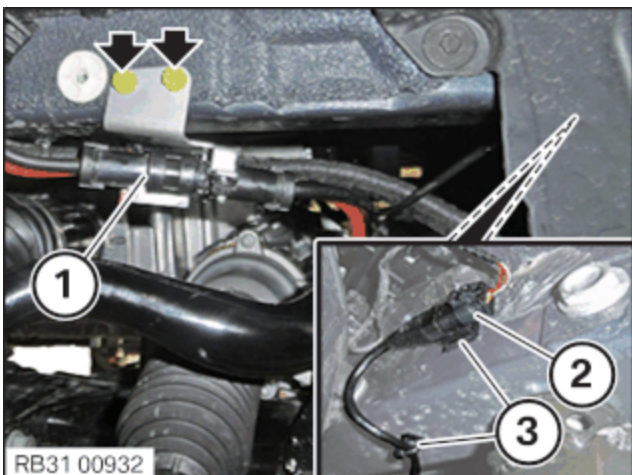

- Unlock plug connection (1) and disconnect.
- Loosen screws (arrows).
- Unlock plug connection (2) and disconnect.
- Detach cables on the holders (3) from the side member.

## 25 – Loosening the universal joint from the steering gear

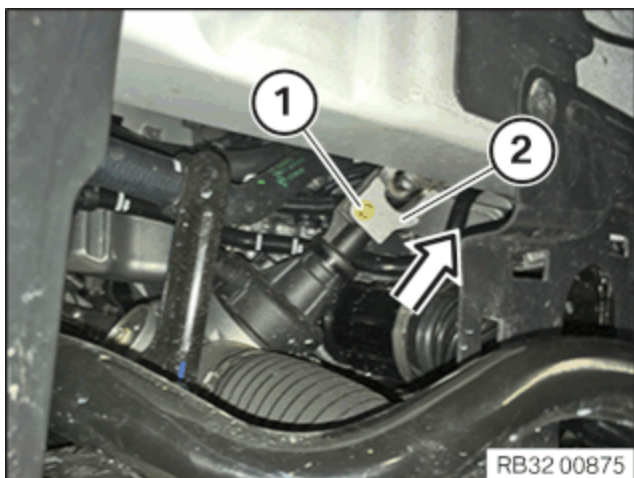

- Loosen screw (1).
- Pull the universal joint (2) off the steering gear in the direction of the arrow.

## 26 – Detach the top left and right wishbone from the swivel bearing



Perform the steps on the left and right side.

### ► Detach the upper wishbone from the swivel bearing

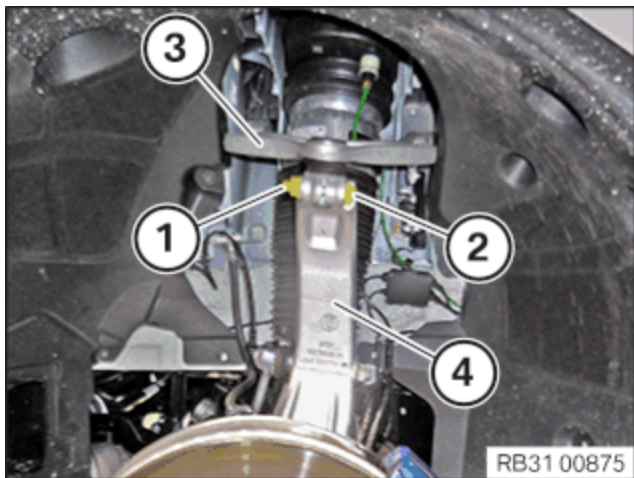

- Unfasten nut (1).
- (2) Pull out screw.
- Detach upper wishbone (3) from the swivel bearing (4).

## 27 – Securing left and right swivel bearings



Perform the steps on the left and right side.

### ► Mounting the swivel bearing

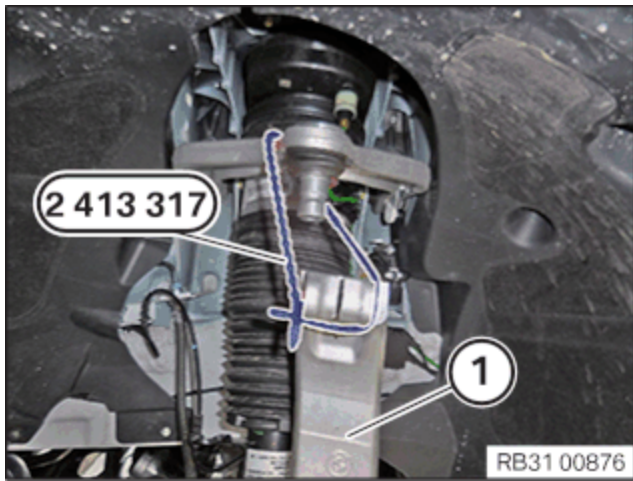

- Secure swivel bearing (1) with special tool **2 413 317** against tilting down outwards.

Do not allow the swivel bearing (1) to hang down from the brake hose.

## 28 – Releasing the right and left spring strut holder from the bottom wishbone



Perform the steps on the left and right side.

### ► Release the spring strut holder from the bottom wishbone

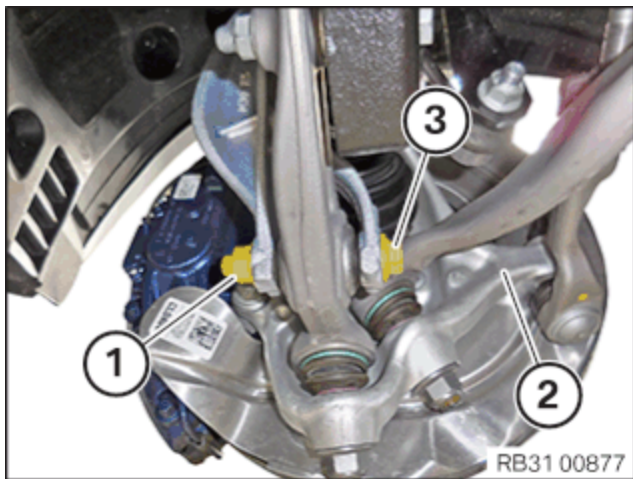

- Unfasten nut (1).
- Punch in the swivel bearing (2) at the front in an inward direction.
- (3) Pull out screw.
- Release the spring strut holder from the bottom wishbone.

## 29 – Disconnecting the connector from the vertical acceleration sensor on the left and right



Description is for left component only. Procedure on the right side is identical.

### ► Disconnecting the connector from the vertical acceleration sensor

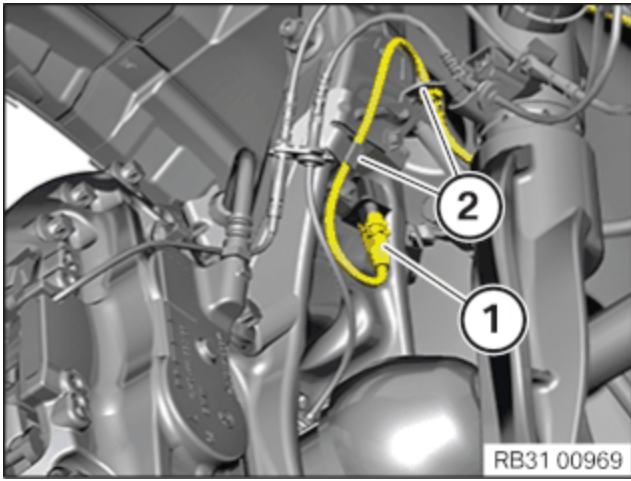

The following step(s) is/are to be carried out if the specified component(s) is/are fitted.

- Unlock plug connection (1) and disconnect.
- Release cable from brackets (2).

### 30 – Disconnect the plug connections on the left and the right

#### ► Disconnect plug connections on the left

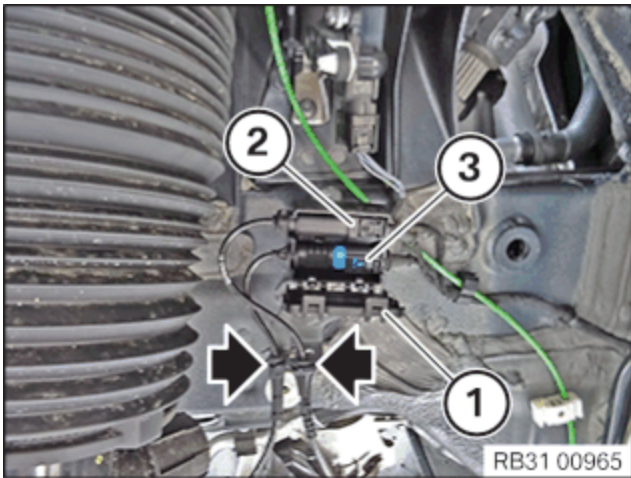

- Open lid (1).
- Unlock and disconnect the plug connections (2) and (3).
- Detach cable from holder (arrows).

#### ► Disconnect the right-hand plug connection

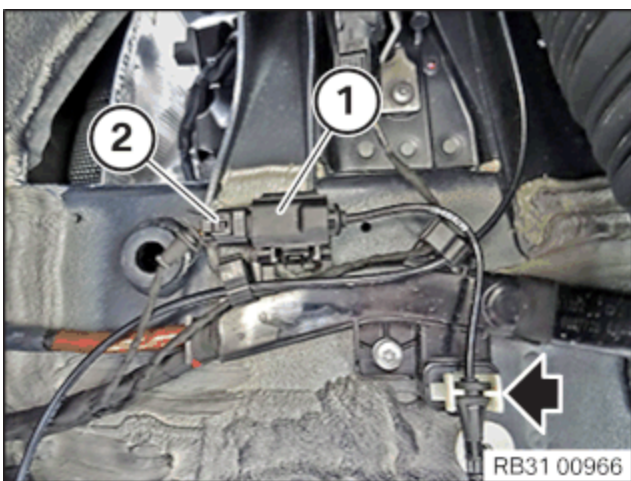

- Open lid (1).
- Unlock plug connection (2) and disconnect.
- Release the cable from the holder (arrow).

## 31 – Release left and right brake caliper and tie up



Perform the steps on the left and right side.

### ► Detach the brake caliper and tie it up

- Release the brake hose (1) from the holders (2).

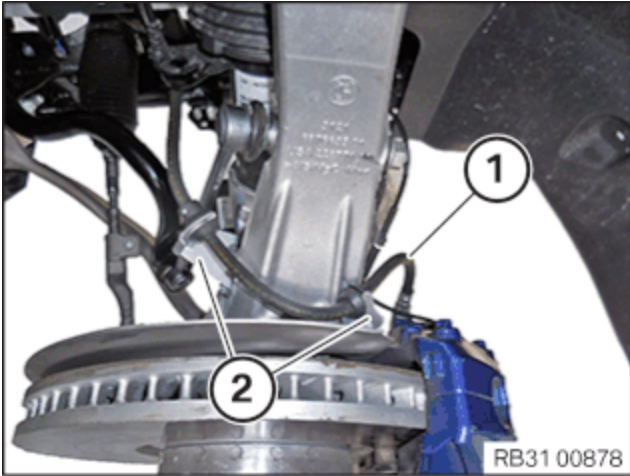

- Detach the cable (2) from the holder (3).
- **Left only:** Detach the cable (1) from the holder (3).

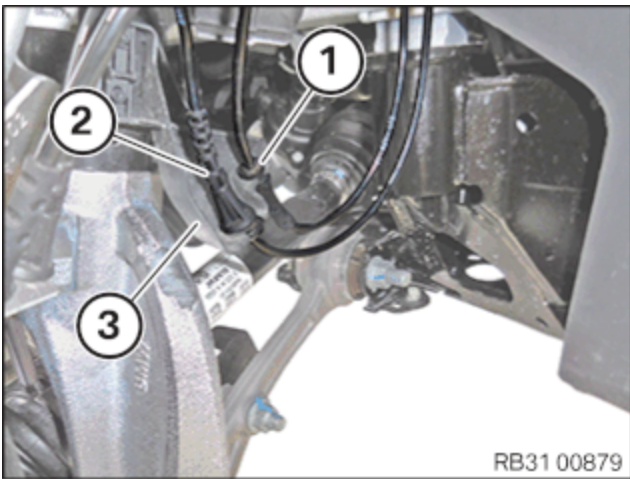

- Loosen screws (1).
- Release the brake caliper (2) from the swivel bearing.

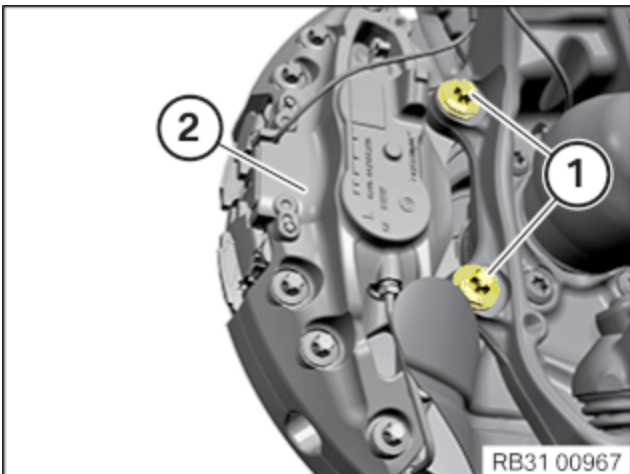

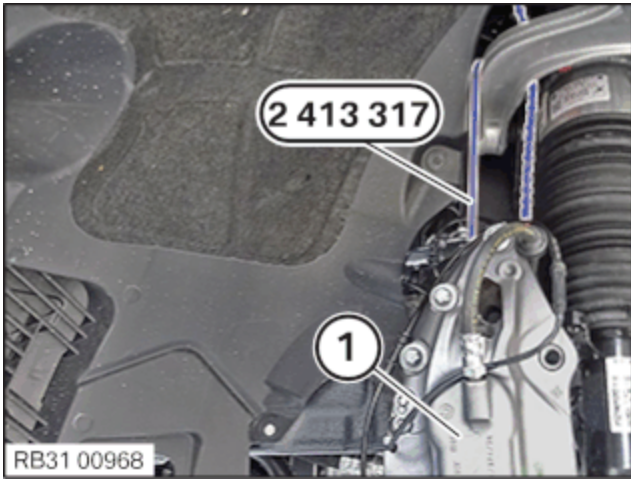

- Tie the brake caliper (1) up with the special tool **2 413 317**.

**Note:** Do not let the brake caliper on the brake hose.

## 32 – Detaching coolant hoses from the front axle support



The following step(s) is/are to be carried out if the specified component(s) is/are fitted.

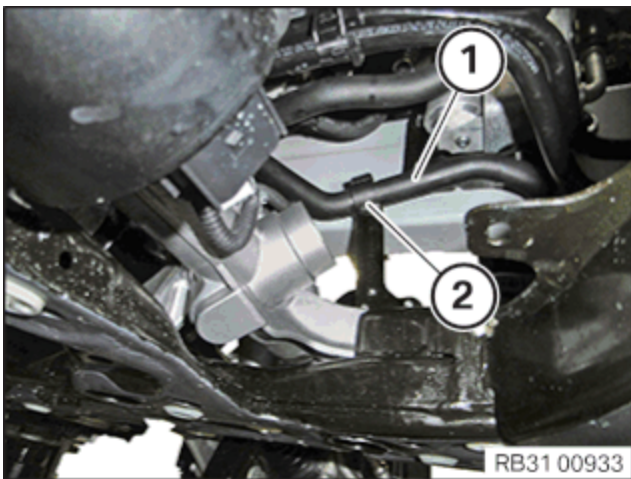

- Remove the coolant line (1) from the holder (2).

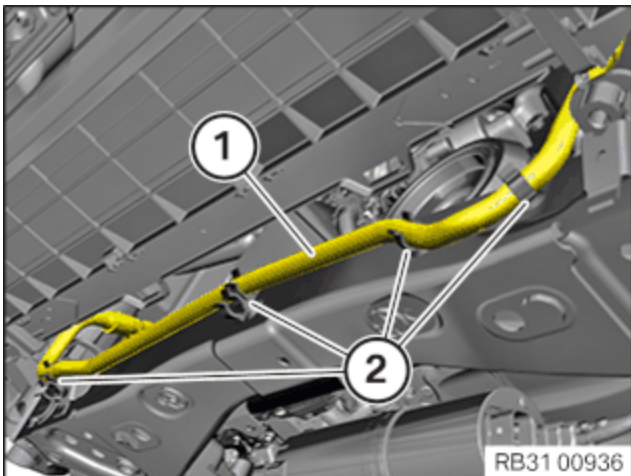

- Detach coolant hose (1) from the brackets (2).

- If installed: Remove the coolant line (1) from the holder (2).

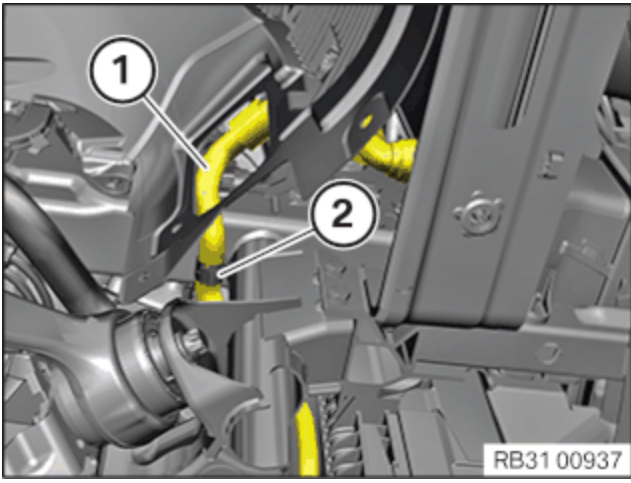

### 33 – Prepare the mobile table lift

#### Mobile table lift

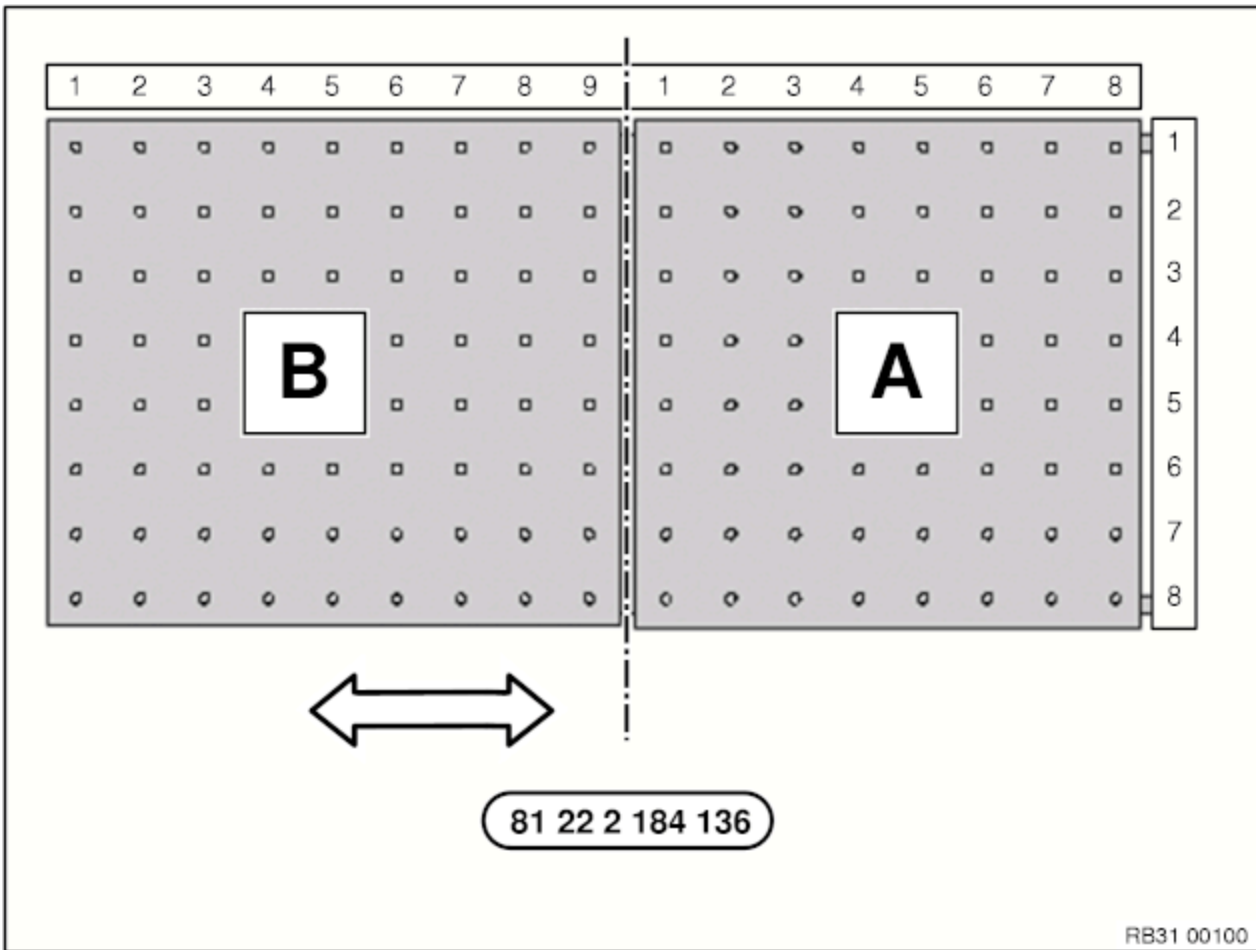

**A** Work surface of the mobile table lift for mounting of the front axle support

**B** Work surface of the mobile table lift (adjustable in length)

- Stage the mobile table lift **2 184 136**.

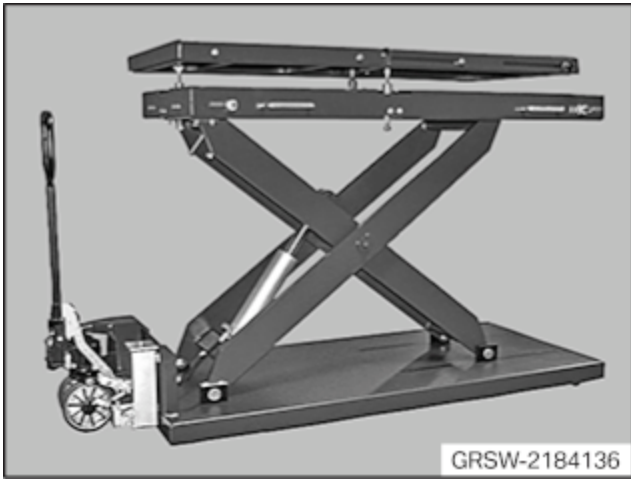

- Place the mounting element from the set of special tools **2 305 379** ready.

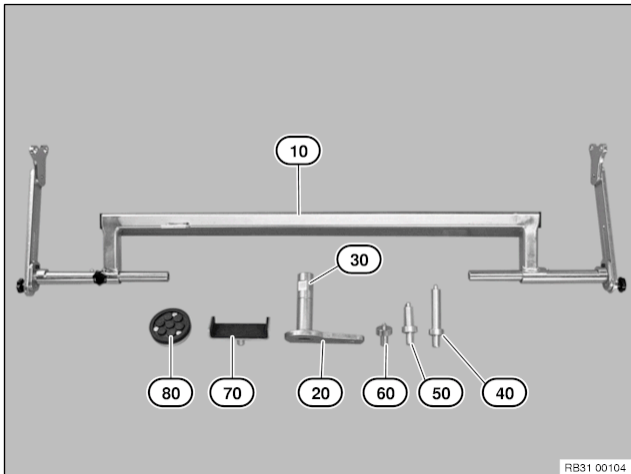

- Position retaining elements (20) on work surface **A** of the mobile lift table.
  - Front axle support, front: **7/2** and **7/7**
  - Front axle support, rear: **1/1** and **1/8**
- Position mounting for the swivel bearing (10) on work surface **A** of the mobile lift table with coordinates **4/1** and **5/8**.

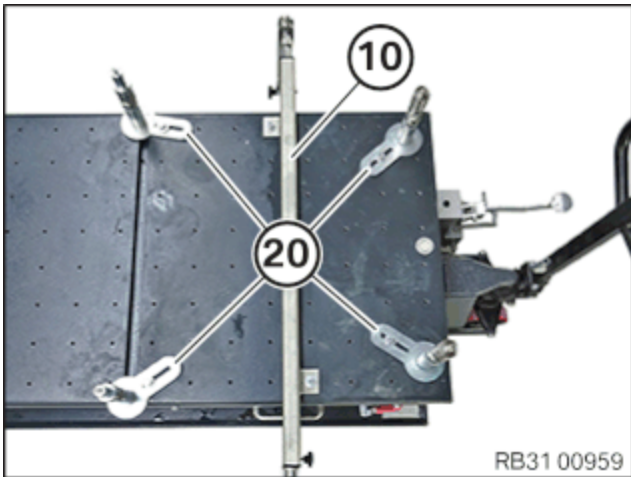

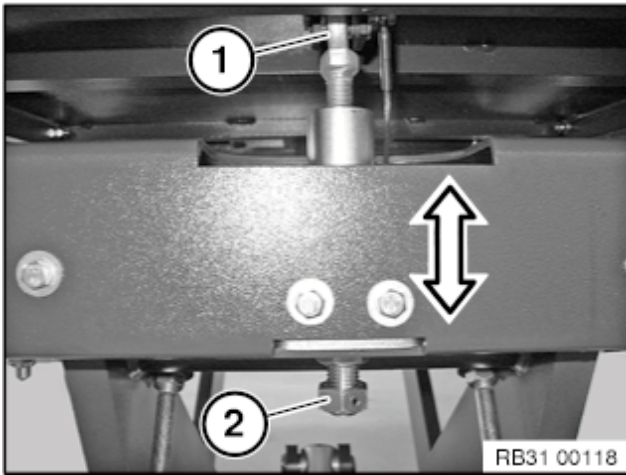

- Adjust the inclination of the lifting table (1) with the adjusting screw (2) until the bubble level of the lifting table (1) shows the correct position.

### 34 – Position the mobile table lift

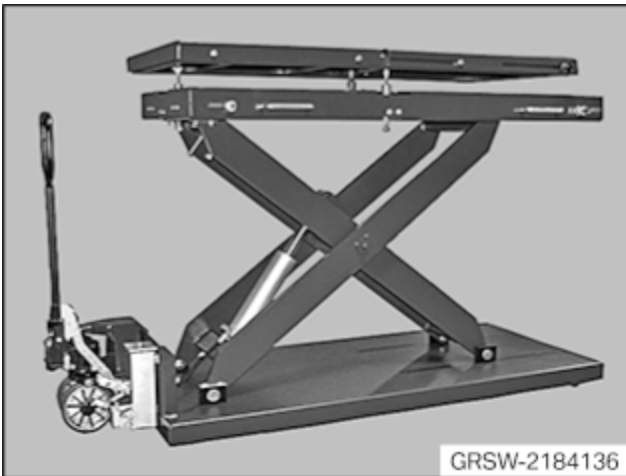

- Position mobile lifting table **2 184 136** centred under vehicle and jack it up.

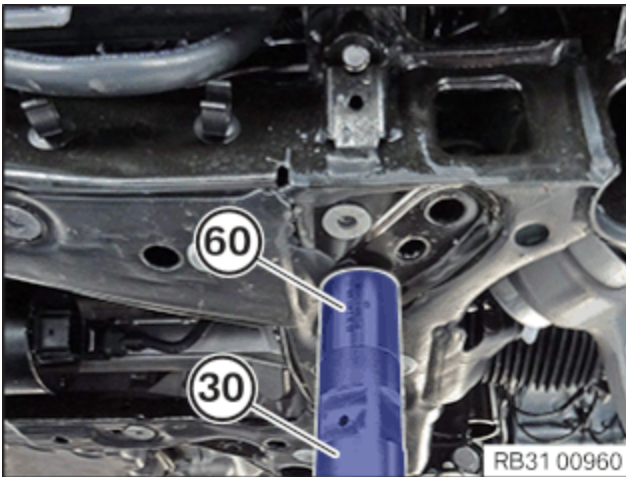

Perform the steps on the left and right side.

- Position adjustable mounting (30) with the adapter (60) on the front axle support at front.

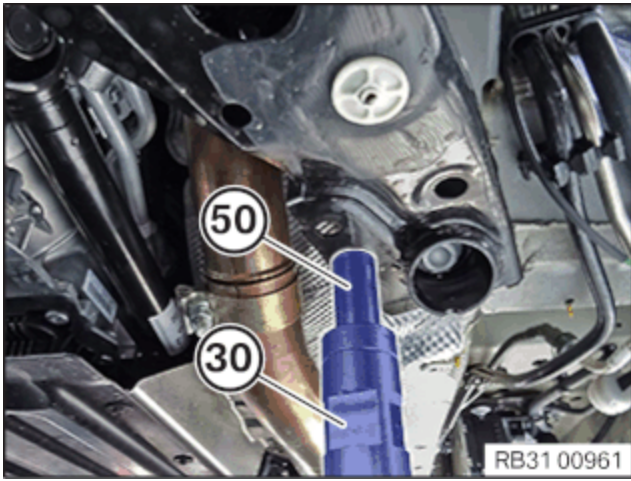

Perform the steps on the left and right side.

- Position adjustable mounting (30) with the adapter (50) on the front axle support at rear.

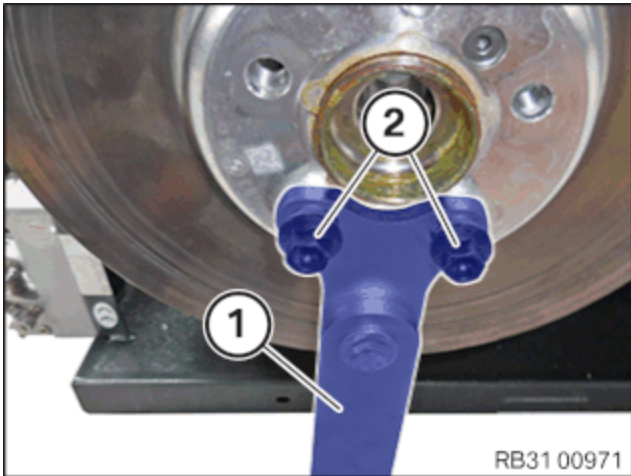

Perform the steps on the left and right side.

- Position the mounting for the swivel bearing (1).
- Hand-tighten the bolts (2).

### 35 – Release left and right swivel bearings



Perform the steps on the left and right side.

#### ► Releasing swivel bearing

- Release the swivel bearing (1) from the special tool 2 413 317 .

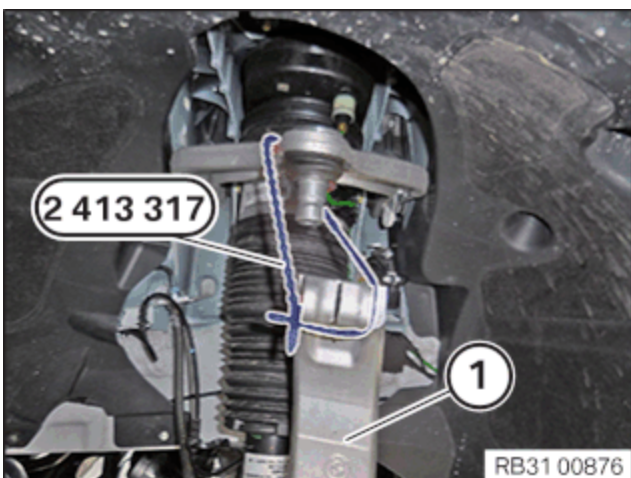

## 36 – Unscrew the bolts on the front axle support



**Falling or tipping of a heavy component.**

**Danger! Life-threatening injuries!**

- Before lowering or removing the front axle: Secure the engine in mounting orientation.
- For additional information see: 11 00 670 Securing engine in installation position.



Perform the steps on the left and right side.

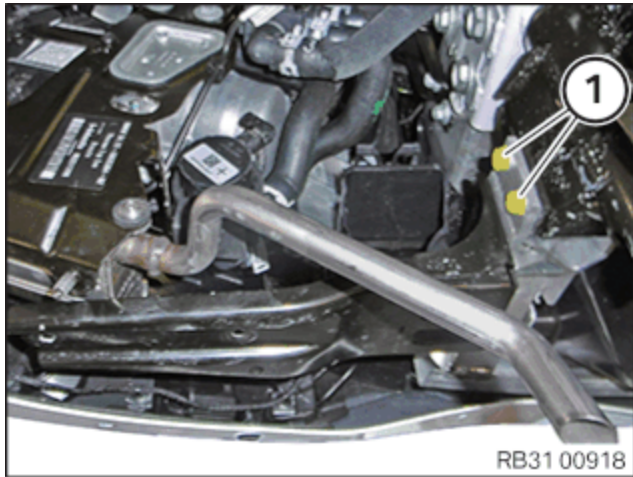

- Loosen screws (1).

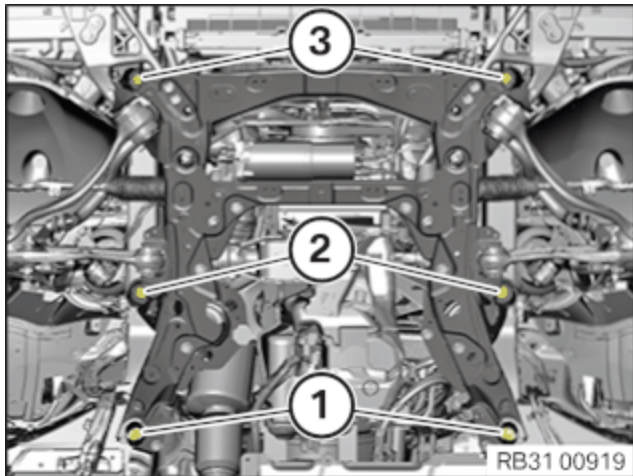

- Loosen screws (1) to (3).

## 37 – Remove front axle

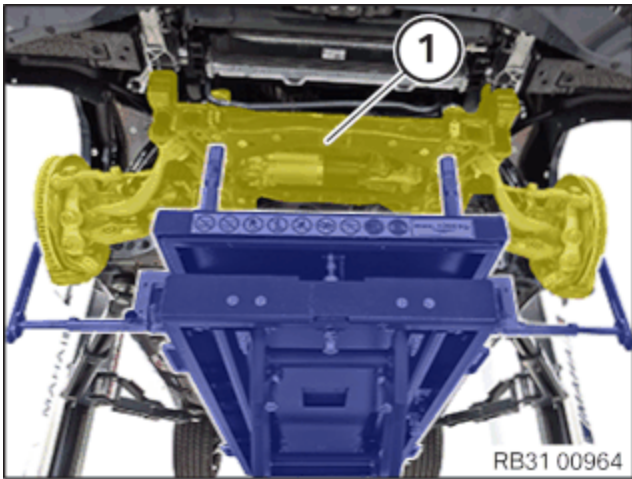

**Insufficient freedom of movement for adjacent components.**

**Damage to adjacent components.**

- When lowering or lifting the subframe, ensure freedom of movement of the adjacent components.
- Lower and remove the front axle (1) using the mobile lifting table.

## 38 – Removing the acoustic cover of the oil sump

### Prerequisite

Disconnect all negative battery cables.



**Working on the 12V vehicle electrical system.**

**Risk of shorting! Risk of fire!**

- Make sure that **no battery charger** is connected to the jump start terminal point in the engine compartment.
- Disconnect negative battery cable from battery.
- With auxiliary batteries: Disconnect negative battery cables from all auxiliary batteries.

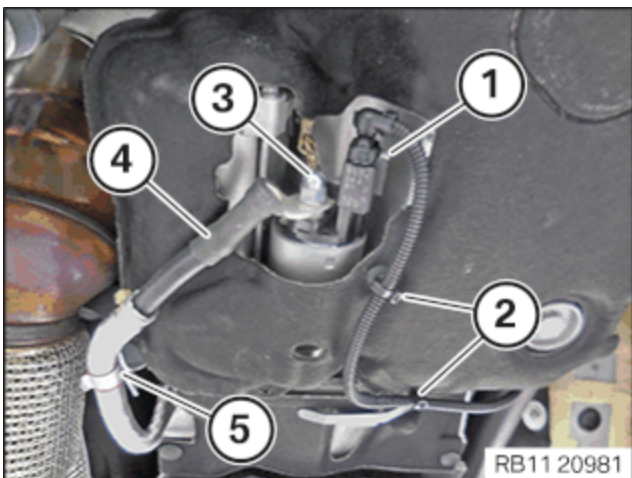

- Unlock plug connection (1) and disconnect.
- Loosen clamps (2).
- Loosen nut (3).
- Guide the positive battery cable (4) out of the clamp (5) and lay to one side.

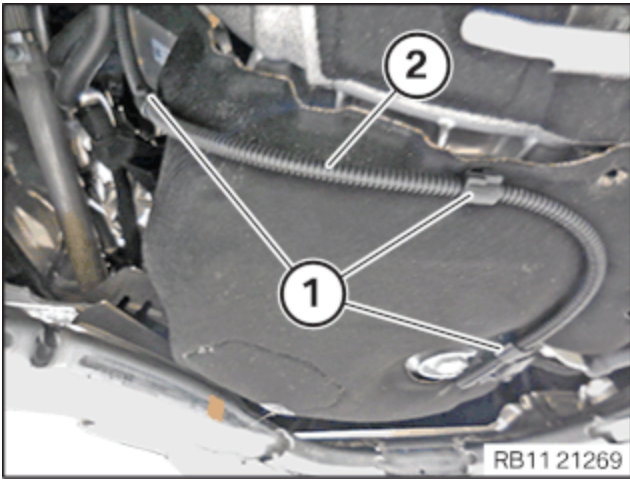

- Unlock and loosen the clamps (1).
- Feed out the wiring harness section (2) for the automatic transmission and set it aside.



The following step(s) is/are to be carried out if the specified component(s) is/are fitted.

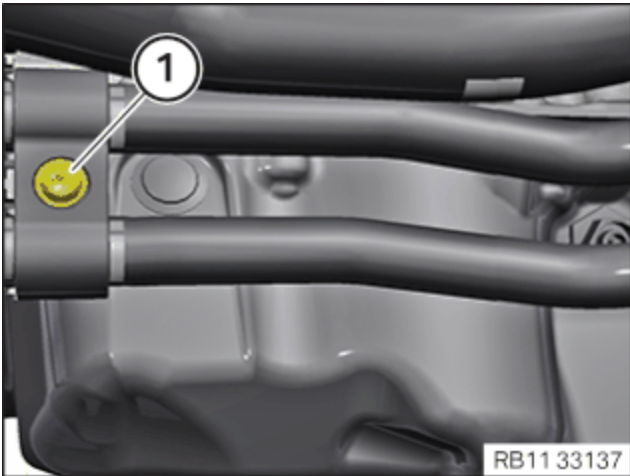

- Loosen screw (1).



The following step(s) is/are to be carried out if the specified component(s) is/are fitted.

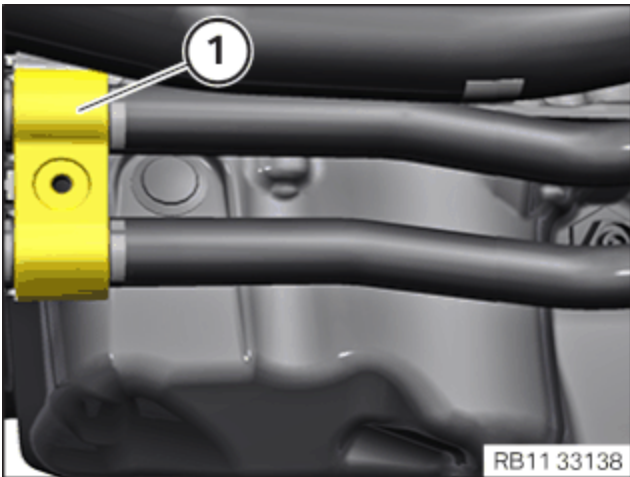

- Loosen the holder (1).



The following step(s) is/are to be carried out if the specified component(s) is/are fitted.

- Feed out transmission oil lines (1) from the holder (2) and place to one side.

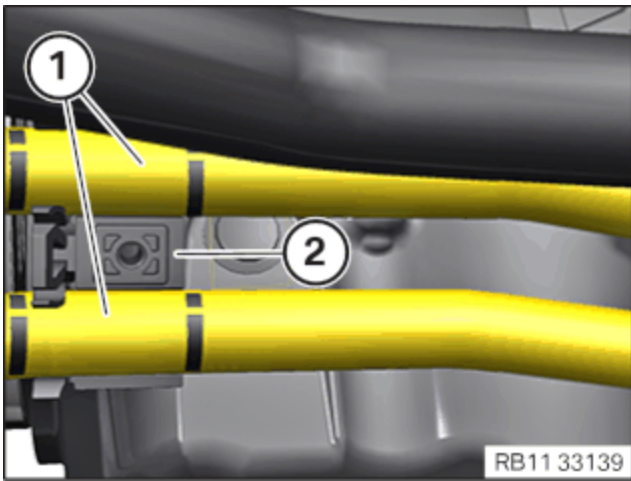

- Release the expanding rivets (1) and (2).

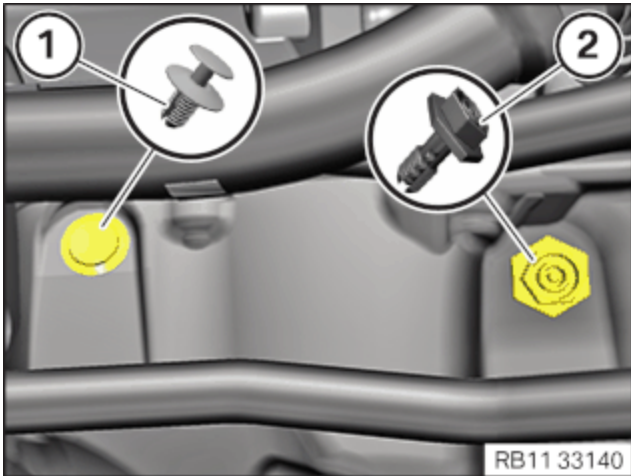

- Release expanding rivet (1).

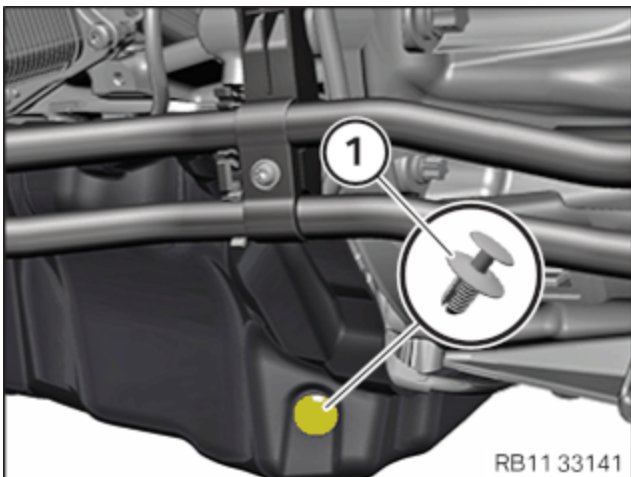

- Undo fir tree clip (1).

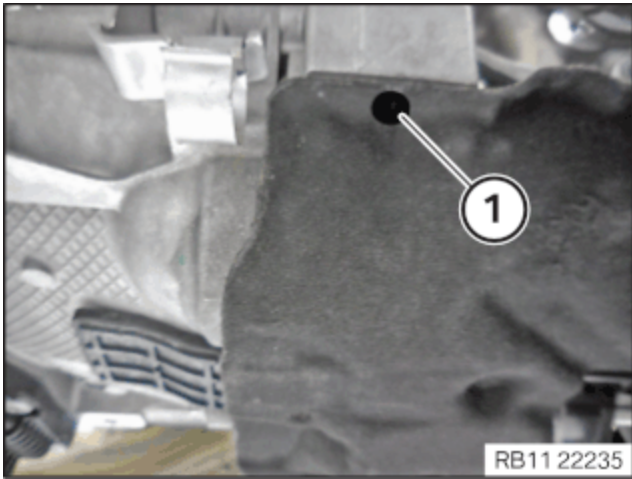

- Release the expanding rivet (1).
- Feed out the oil sump acoustic cover (2) and remove.

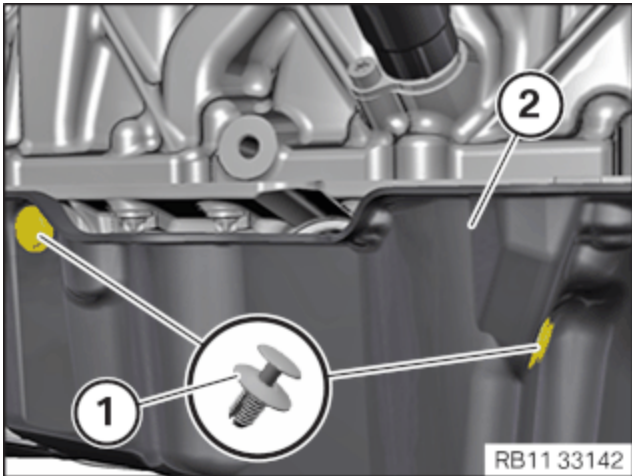

## 39 – Removing starter motor

### Prerequisite

Acoustic cover of the oil sump has been removed.



**Hot surfaces.**

**Risk of burning!**

- Perform all work only on components that have cooled down.



### Electrostatic discharge.

#### Damage to or destruction of electrical components.

- Leave electrical components in original packaging until just before they are installed. Use the original packaging only for any return shipments. Always package removed components straight away.
- Comply with user information on applying the associated special tool 12 7 060.
- Only touch the housings of electrical components. Do not touch pins or multi-pin connectors directly.
- Wear electrically conductive clothing and antistatic shoes (with ESD symbol).
- For additional information see: 61 35 ... Notes for ESD protection (electrostatic discharge)

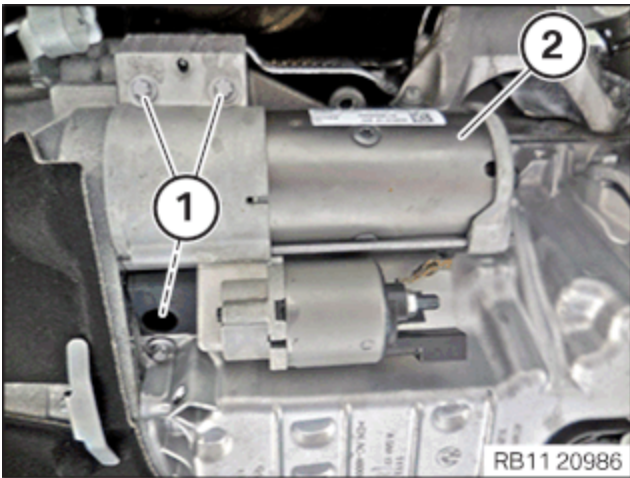

- Loosen screws (1).
- Feed out and remove the starter motor (2).

## 40 – Remove oil sump



### Contaminant or foreign body.

#### Contamination can result in malfunction, operating failure or leak.

- Adhere to the utmost cleanliness.
- Protect components from contamination, e.g., by covering.
- Seal off cable connections with seal plugs.



Collect and dispose of emerging fluids. Observe country-specific waste disposal regulations.

- Unlock clamps (arrows) and disconnect.
- Unlock and release plug connection (1).

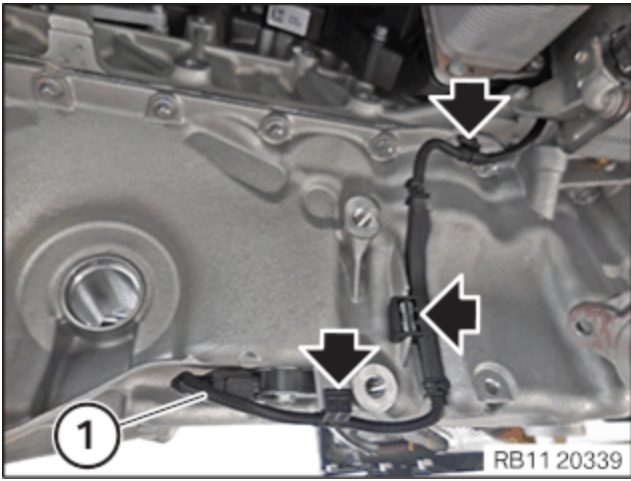

- Loosen clamp (1).
- Thread the sealing cap (2) out and remove.

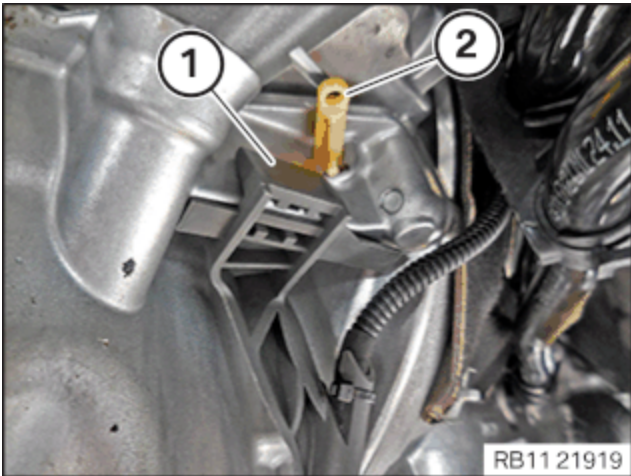

- Unscrew the transmission bolts (1).

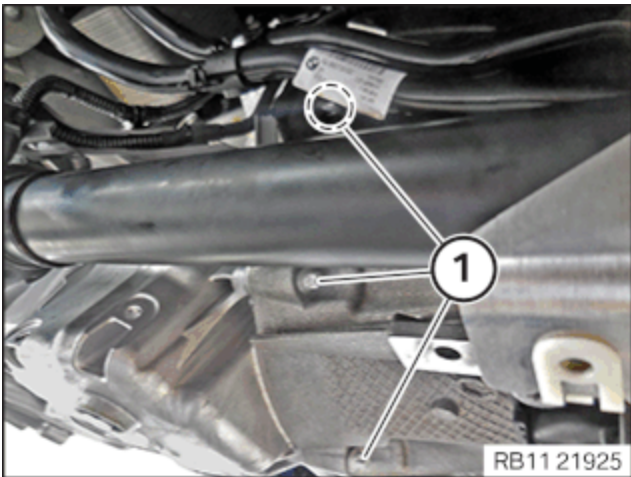

- Loosen screws (1).

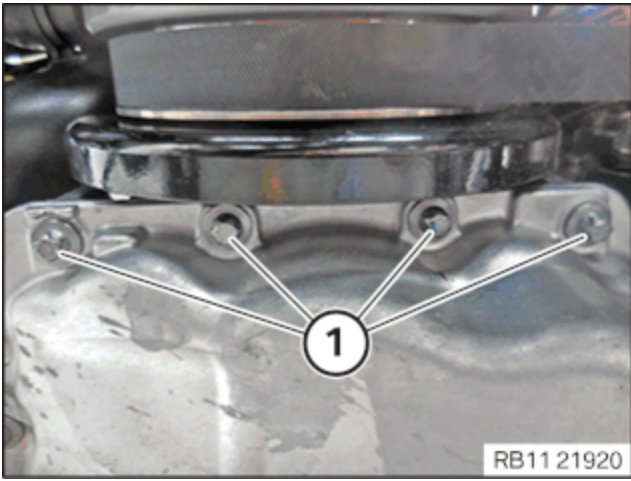

- Loosen screws (1).

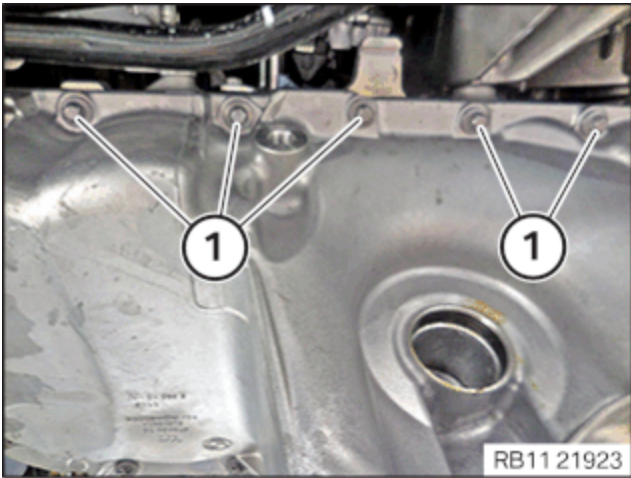

- Loosen screws (1).

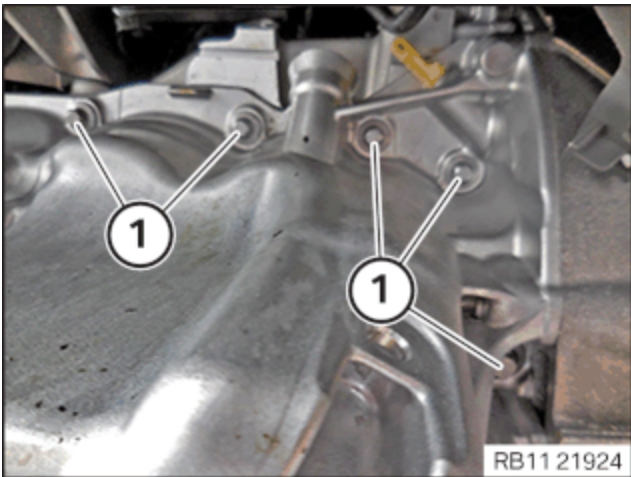

- Loosen screws (1).

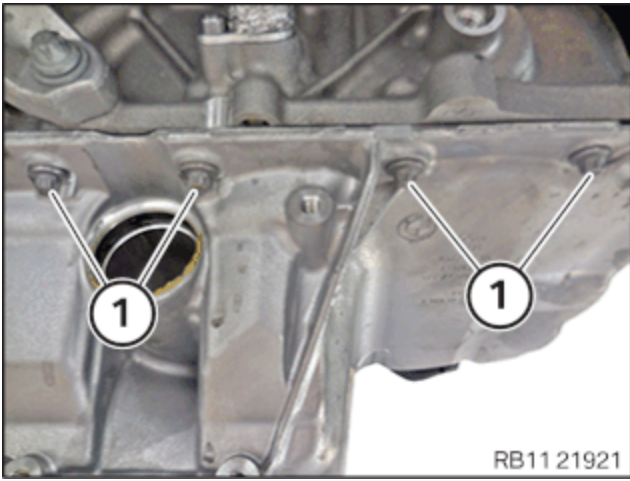

- Loosen screws (1).

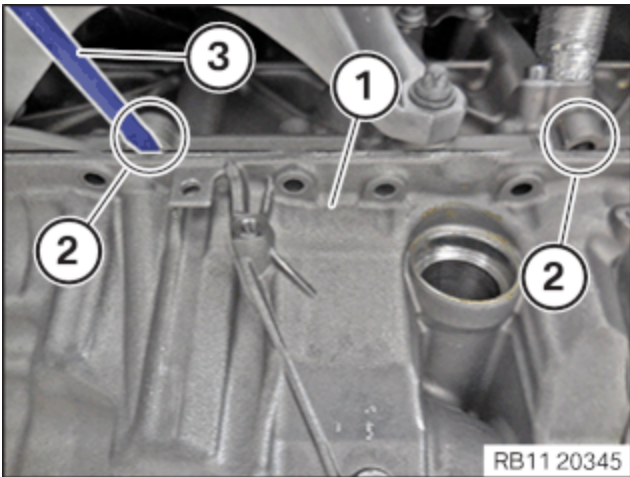
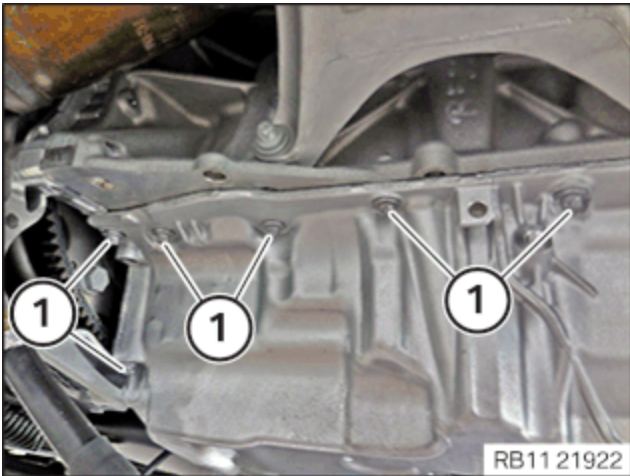

**i**

Increased effort may be necessary during disassembly because the component is bonded with liquid sealing compound.

- Release the oil sump (1) in the **marked** areas (2) using suitable tools (3).
- Guide out the oil sump (1) downwards to the rear and remove.

## MAIN WORK

## 41 – Remove oil pump



### Contaminant or foreign body.

Contamination can result in malfunction, operating failure or leak.

- Adhere to the utmost cleanliness.
- Protect components from contamination, e.g., by covering.
- Seal off cable connections with seal plugs.

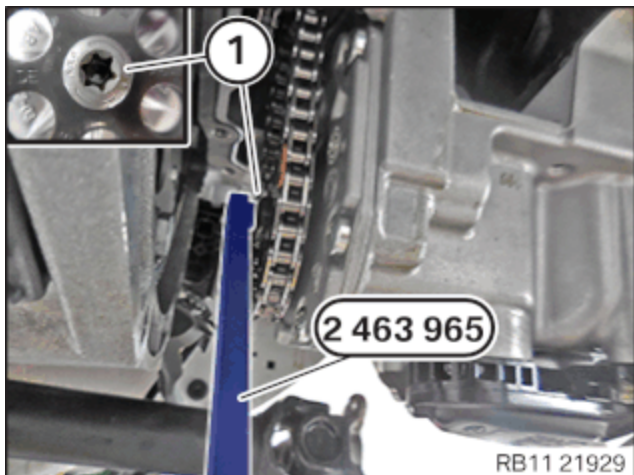

**i**

The thread is a left-hand thread.

- Release the screw (1) using the special tool **2 463 965**.
- Thread out the bolt (1) and remove it.

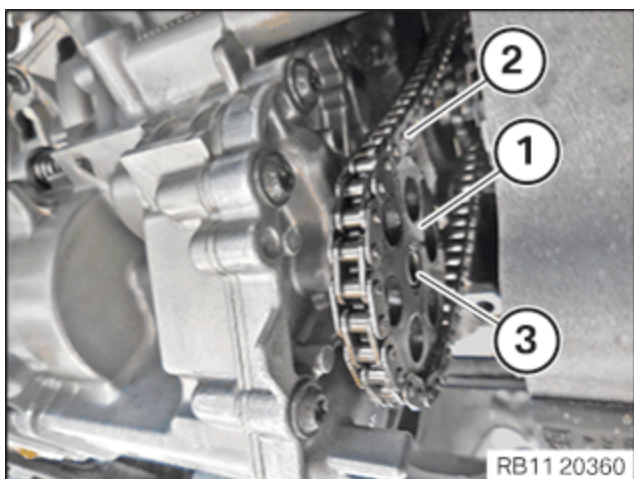

- Release the camshaft sprocket (1) from the oil pump (3).
- Feed the camshaft sprocket (1) out of the drive chain (2) and remove it.

**i**

Collect and dispose of emerging fluids. Observe country-specific waste disposal regulations.

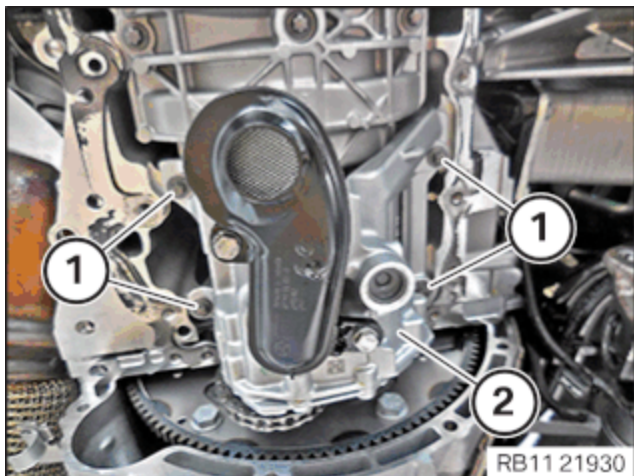

- Loosen the screws (1) on the oil pump (2).
- Feed out the oil pump (2) and remove.

## 42 – Replacement: Replace the oil pump

- Renew the oil pump.

**Parts:** Oil pump

## 43 – Installing the oil pump

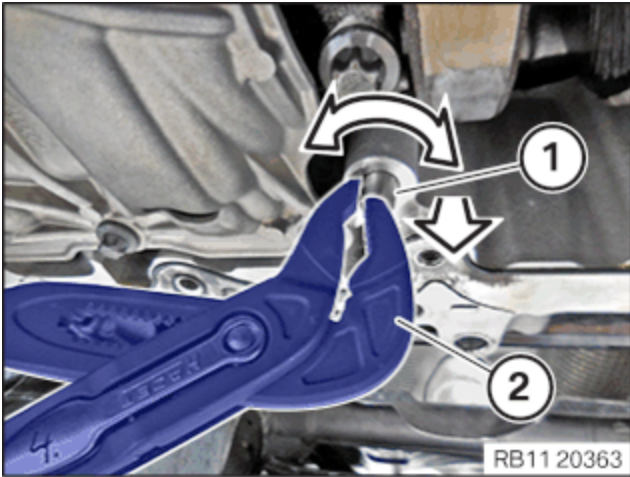

- Work centering sleeves (1) out of the crankcase in the direction of the arrow using conventional tools (2) and remove.
- Replace centering sleeves (1).

**Parts:** Centring sleeves

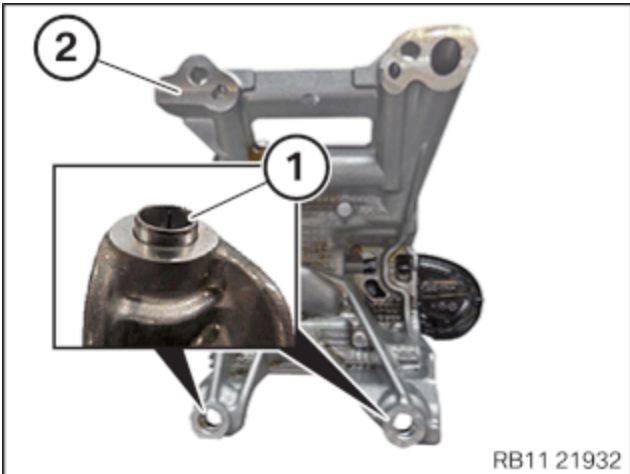

- Guide in and install new centering sleeves (1) on oil pump (2).

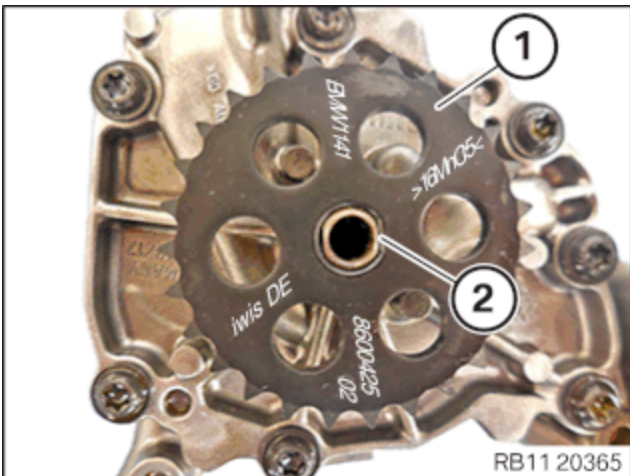

- Position camshaft sprocket (1) on oil pump (2).  
The labelling on camshaft sprocket (1) must pull away from oil pump (2).

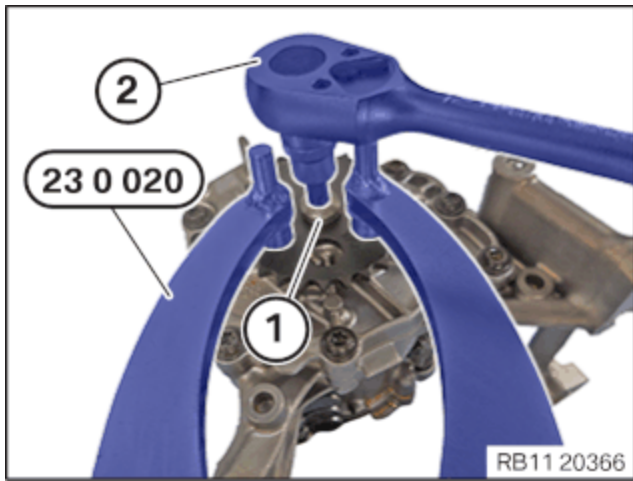

- Replace screw (1).

**Parts: Screw**



The thread is a left-hand thread.

- Insert bolt (1) and fit.



Conduct the following step with the assistance of an auxiliary person.

- Hold camshaft sprocket with special tool **0 491 440 (23 0 020)** and tighten bolt (1) with conventional tools (2).

**Sprocket to oil pump**

M8	Important - left-hand thread Renew screw.	1. Tightening torque	5 Nm
		2. Angle of rotation	90 °

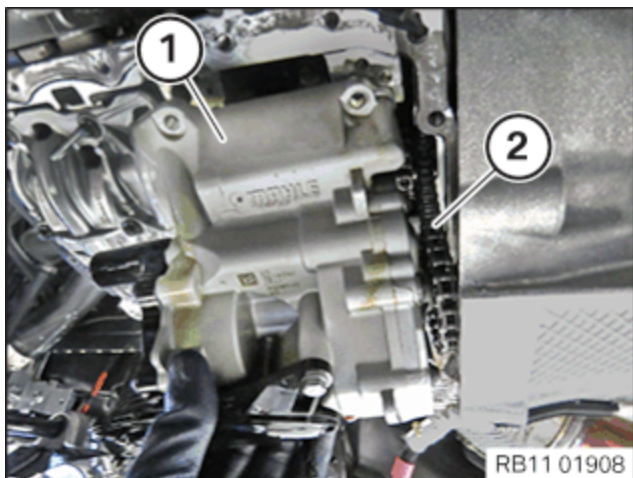

- Guide oil pump (1) into drive chain (2) and position it.

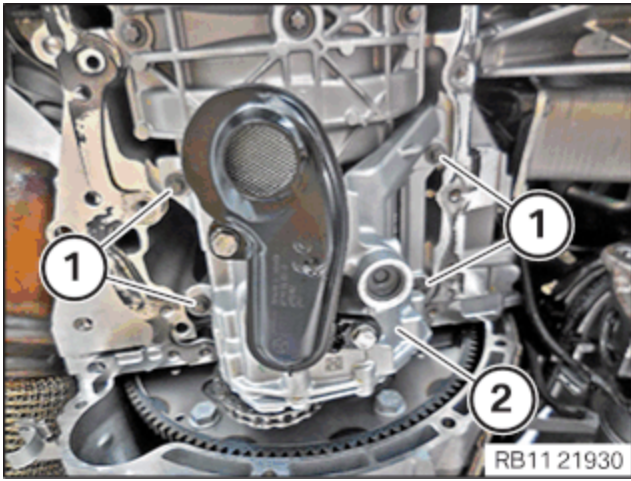

- Replace the screws (1).

**Parts: Screws**

- Tighten the screws (1).

**Oil pump to crankcase**

M8	Renew screw.	1. Jointing torque	15 Nm
		2. Angle of rotation	45 °

## POSTPROCESSES

### 44 – Installing the oil sump



**Contaminant or foreign body.**

**Contamination can result in malfunction, operating failure or leak.**

- Adhere to the utmost cleanliness.
- Protect components from contamination, e.g., by covering.
- Seal off cable connections with seal plugs.



**Damage to the surface.**

**The use of metal-cutting tools (e.g., emery cloth) to clean the surfaces can damage them and lead to leaks or engine damage.**

- Do not use any metal-cutting tools.

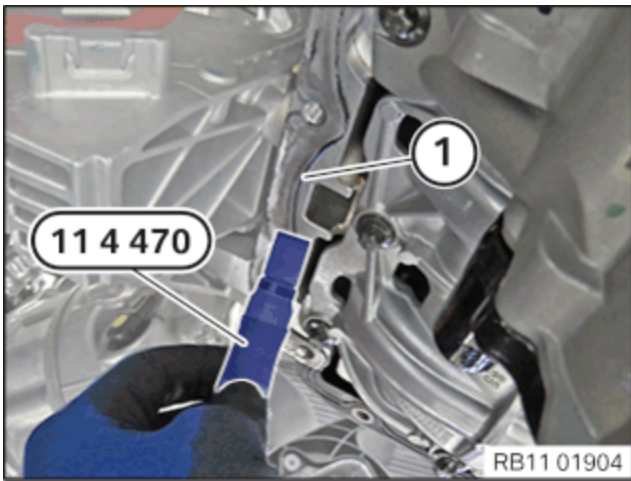

**i**

The sealing surfaces must be free from oils, grease and cleaning agents.

- Remove the coarse sealing residue on sealing surface (1) on the crankcase with special tool **0 495 102 (11 4 470)**.
- Clean sealing surface (1) with the brake cleaner.

#### Expendable materials

Brake cleaner	500 ml, Spray can	83 19 5A260A6
	20 l, Canister	83192365215

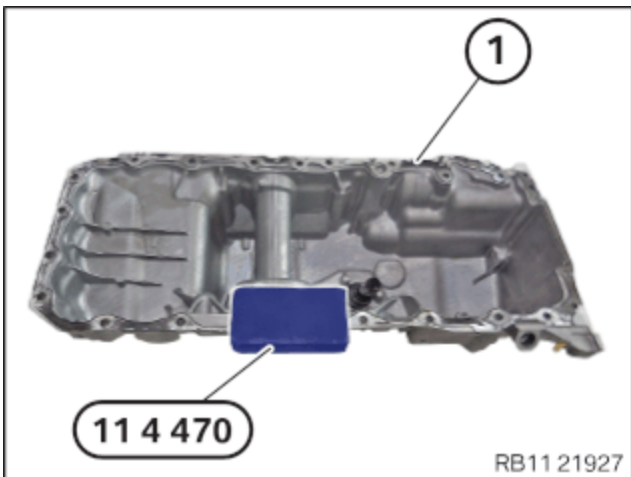

**i**

The sealing surfaces must be free from oils, grease and cleaning agents.

- Remove the fine seal remains on the sealing surface (1) of the oil sump with the special tool **0 495 102 (11 4 470)**.
- Clean sealing surface (1) with the brake cleaner.

#### Expendable materials

Brake cleaner	500 ml, Spray can	83 19 5A260A6
	20 l, Canister	83192365215

- Have the special tool **2 469 803** ready.

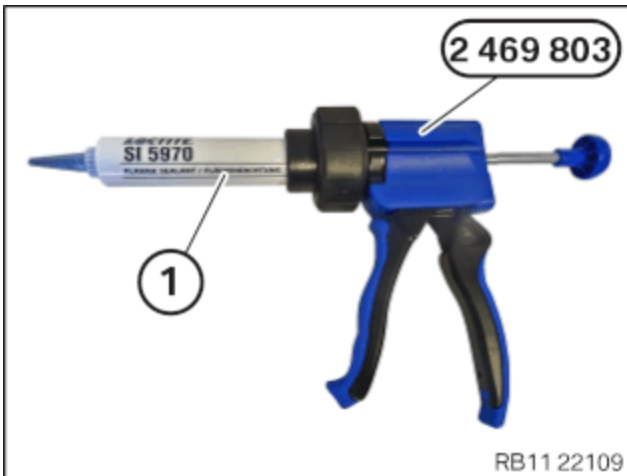

For additional information see: 11 00 ... Overview of consumables in Electronic Parts Catalogue

- Position the sealant (1) on special tool **2 469 803** as shown.

**Parts:** Sealant

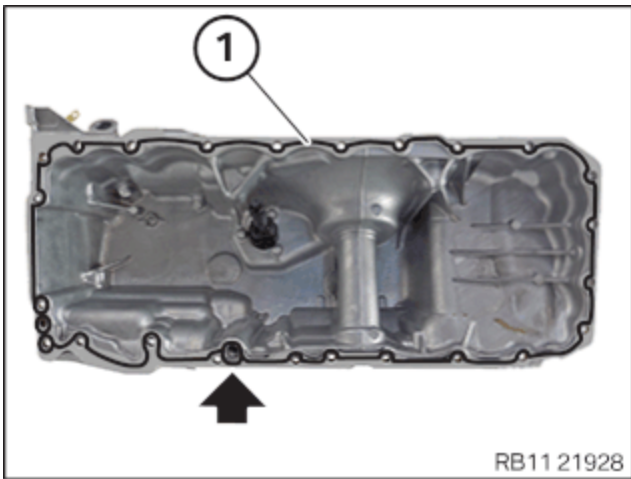

**i**

- The application time of the liquid sealing compound cannot exceed a maximum of 10 min.
  - Start-up of the assembly is not possible until 25 minutes after the application time.
  - Failure to comply with this instruction may result in leaks at the assembly.
- Apply sealing bead (1) with the sealing compound in the **marked** area along the inner edge.

### Sealing compound

Loctite 5970 liquid sealing compound 50 ml, 83190404517  
Cartridge

**Application time**  
**<10 minutes at room temperature**

Overview of consumables (Electronic Parts Catalogue - EPC)

### Height of the sealing bead

2,0 mm ... 2,5 mm

- Completely encircle the oil return orifice (arrow) with the sealant.

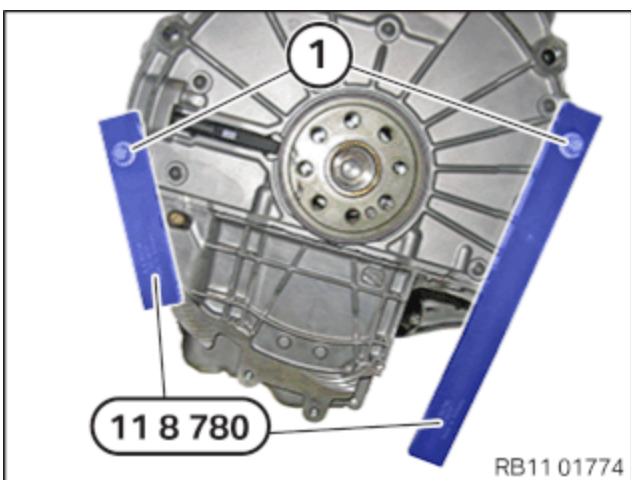

**i**

The special tool 11 8 780 is only required when the transmission is removed.

- Position the special tool **0 496 120 (11 8 780)** with the transmission bolts (1) so that the oil sump is exactly flush with the timing case cover.
- Renew the centring sleeves where required.

- Insert oil sump (1) upwards and forwards and position.

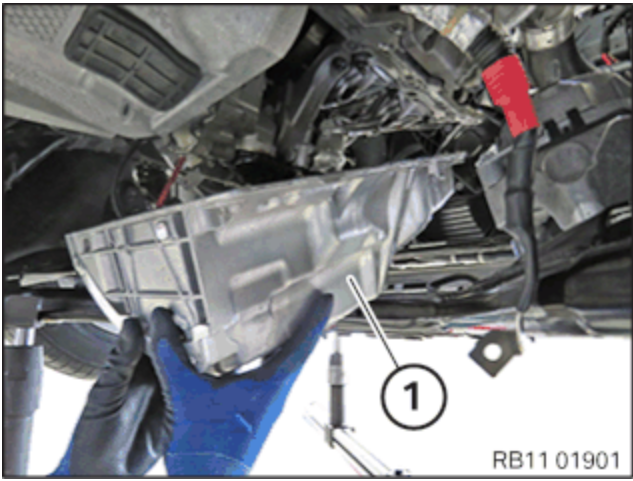

- Tighten the screws (1).

**Oil sump to crankcase**

M8 x 30	Tightening torque	24 Nm
---------	-------------------	-------

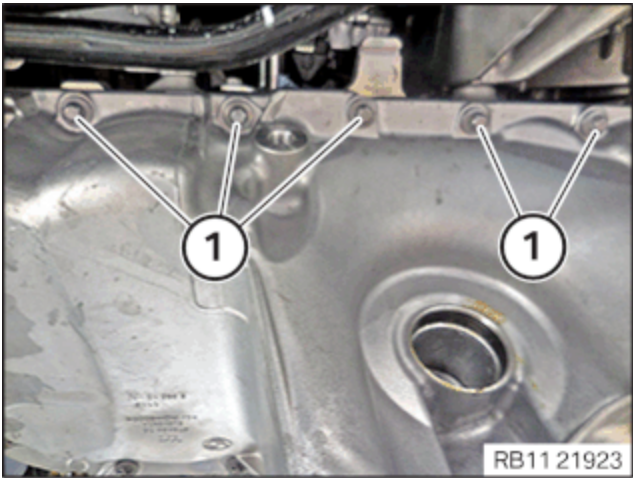

- Tighten the screws (1).

**Oil sump to crankcase**

M8 x 30	Tightening torque	24 Nm
---------	-------------------	-------

**Oil sump to crankcase**

M8 x 110	Tightening torque	24 Nm
----------	-------------------	-------

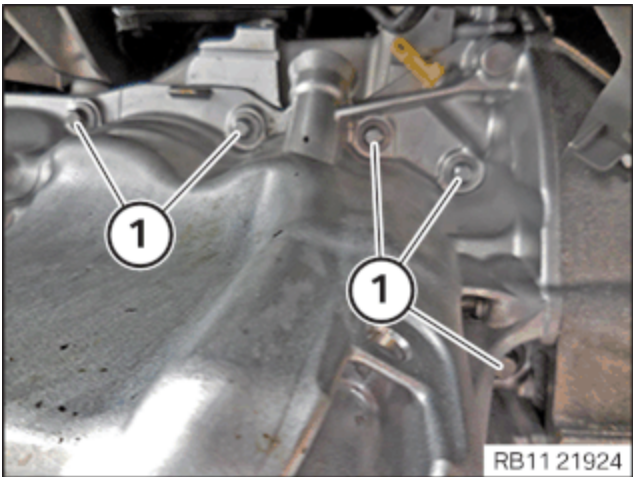

- Tighten the screws (1).

**Oil sump to crankcase**

M8 x 30	Tightening torque	24 Nm
---------	-------------------	-------

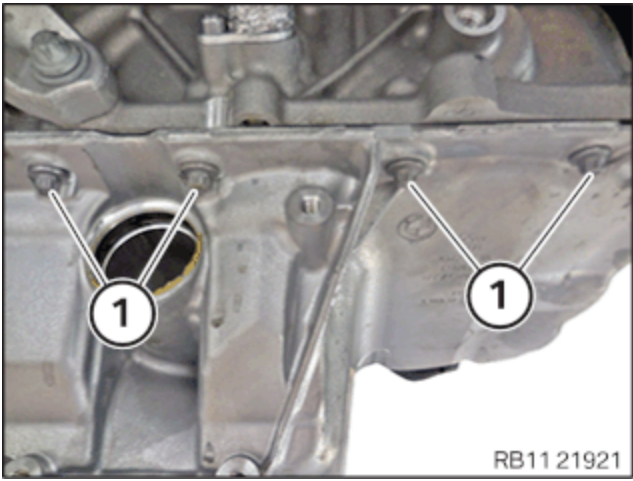

- Tighten the screws (1).

**Oil sump to crankcase**

M8 x 30	Tightening torque	24 Nm
---------	-------------------	-------

**Oil sump to crankcase**

M8 x 110	Tightening torque	24 Nm
----------	-------------------	-------

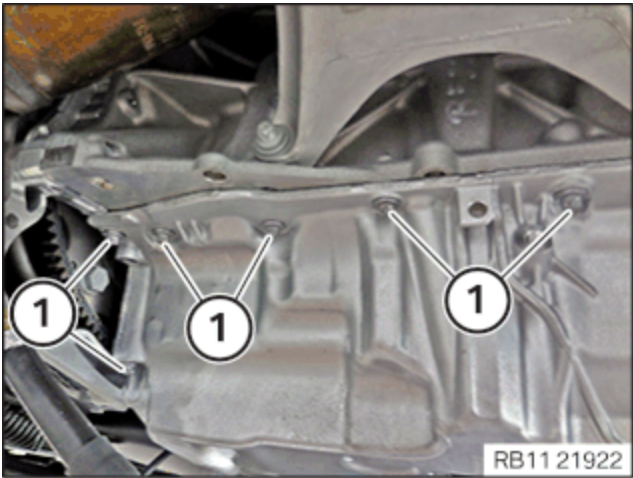

- Tighten the screws (1).

**Oil sump to crankcase**

M8 x 30	Tightening torque	24 Nm
---------	-------------------	-------

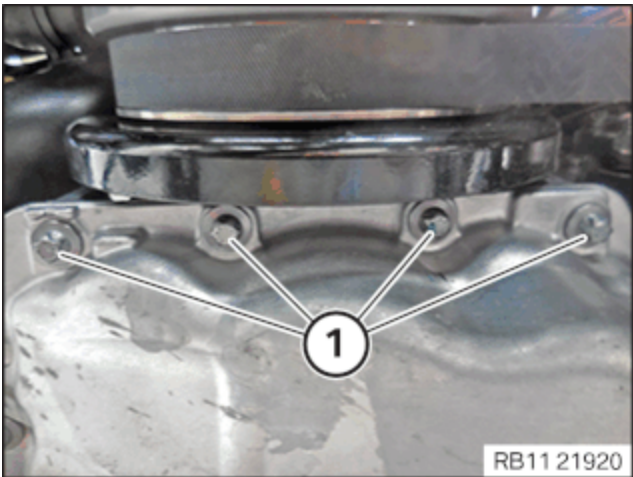

- Tighten transmission bolts (1).

### Transmission to oil sump (manual transmission and automatic transmission)

M8 x 50

Tightening  
torque

19 Nm

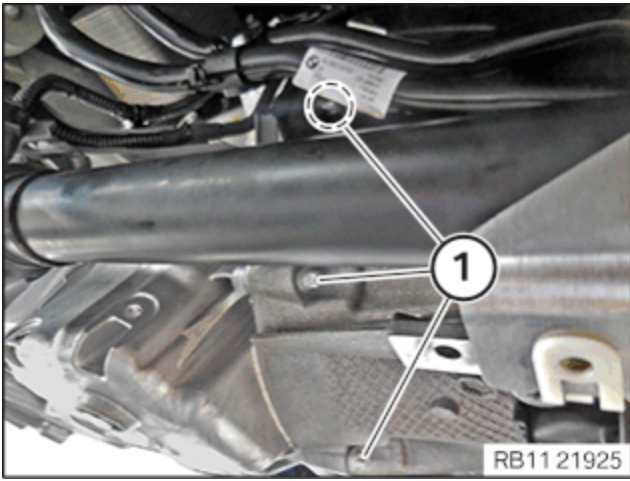

- Secure the clamps (arrows).
- Connect and lock the connector (1).
- Make sure the connector (1) engages audibly.

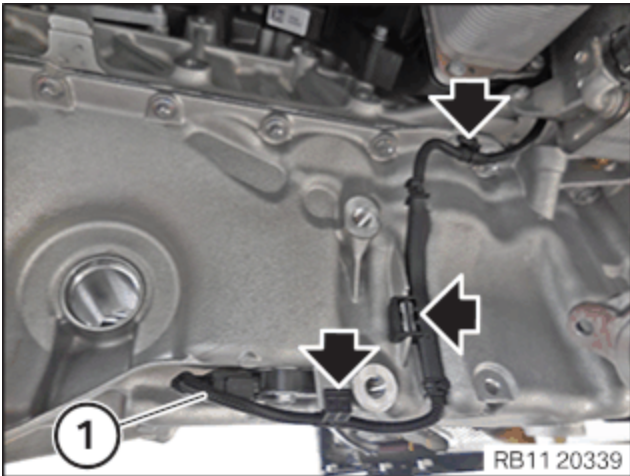

- Mount clamps (1).
- Guide in and install sealing cap (2).

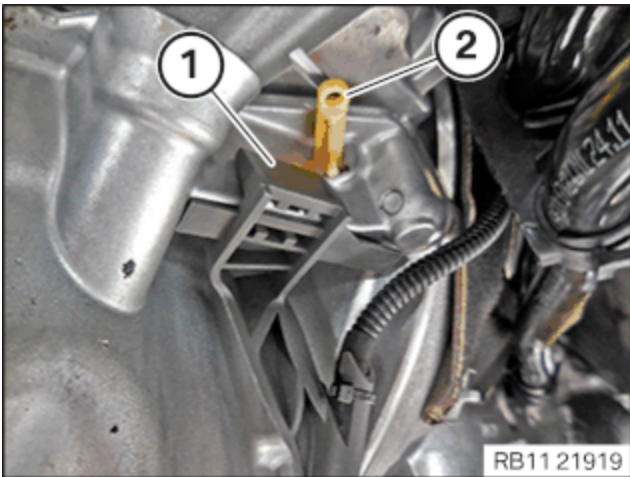

## 45 – Installing starter motor

### Prerequisite

Acoustic cover of the oil sump has been removed.

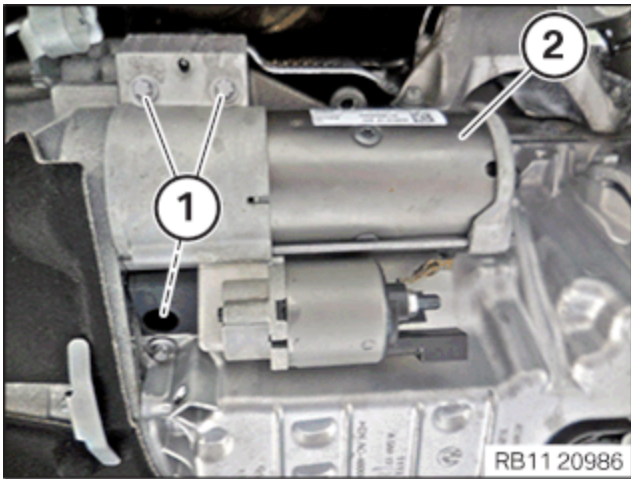

- Insert and install the starter motor (2).
- Tighten the screws (1).

#### Starter motor to crankcase

M8x60

Tightening  
torque

19 Nm

### 46 – Installing the acoustic cover for the oil sump

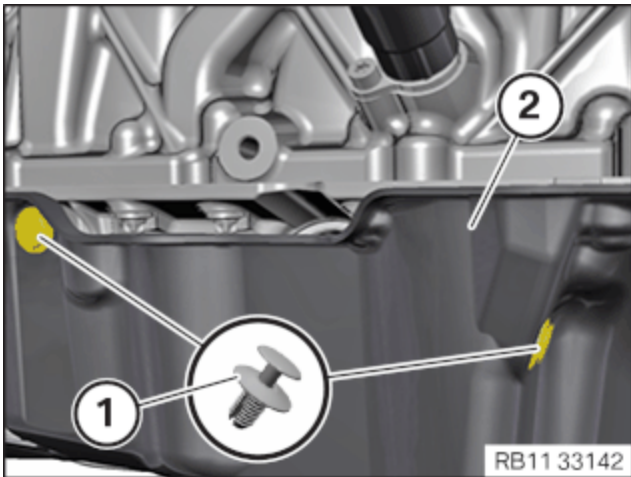

- Feed in and install the acoustic cover (2) of the oil sump.
- Secure expanding rivet (1).

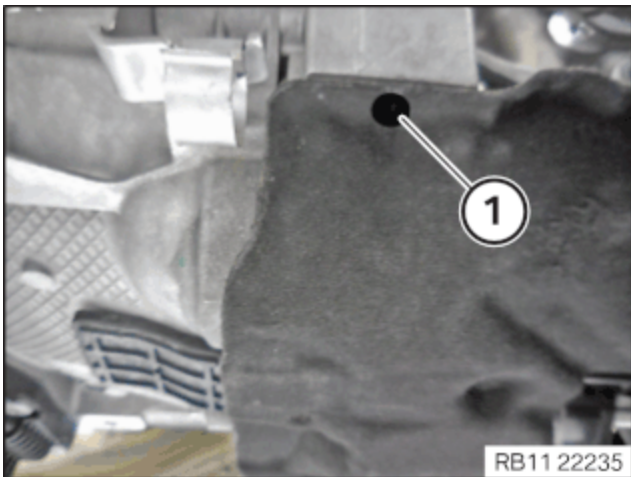

- Check fir tree clip (1) for damage, renew if necessary.
- Parts:** Fir tree clip
- Secure the fir tree clip (1).

- Secure expanding rivets (1) and (2).

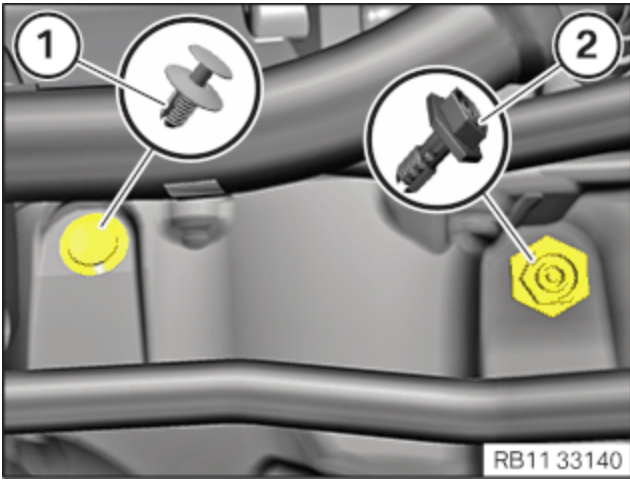

- Secure expanding rivet (1).

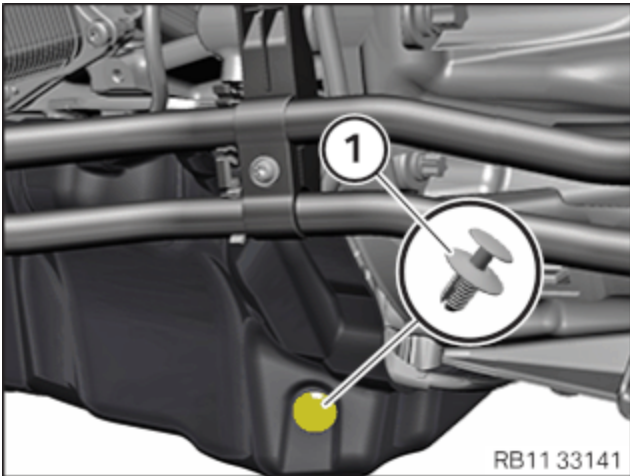

The following step(s) is/are to be carried out if the specified component(s) is/are fitted.

- Position transmission oil lines (1) at the holder (2).  
Ensure that the marks (3) are correctly positioned on the holder (2).

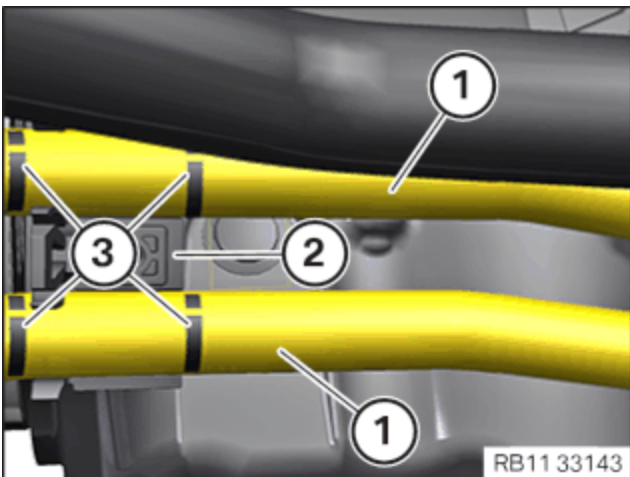

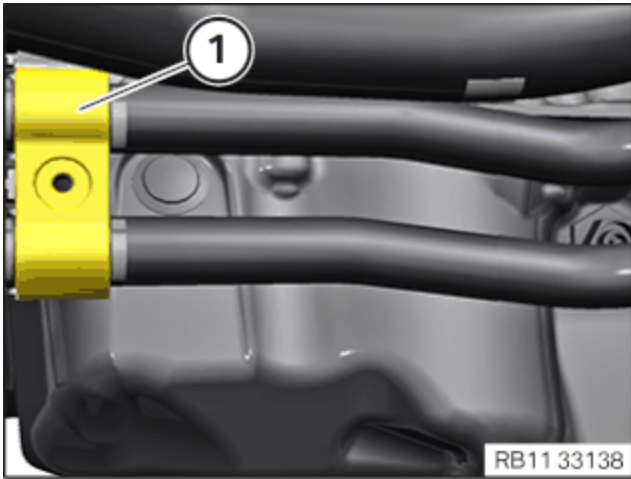

The following step(s) is/are to be carried out if the specified component(s) is/are fitted.

- Insert and install the holder (1).

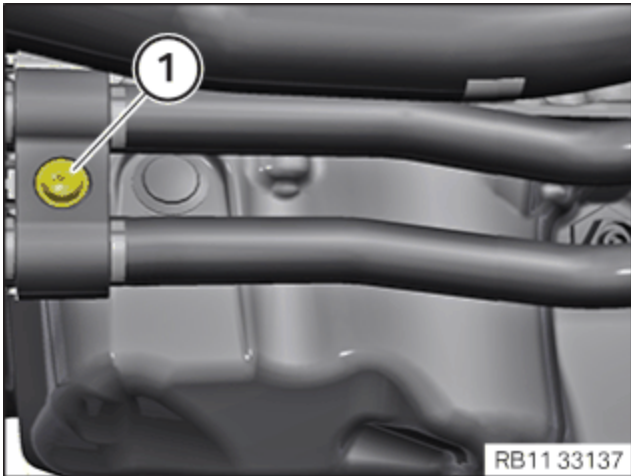

The following step(s) is/are to be carried out if the specified component(s) is/are fitted.

- Tighten the screw (1).

#### Holder for transmission oil line

Screw	Tightening torque	4 Nm

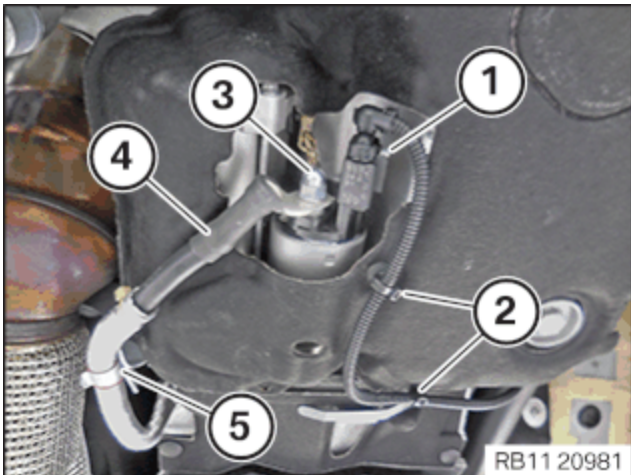

- Connect and lock the connector (1).
- Make sure the connector (1) engages audibly.
- Mount clamps (2).
- Insert and install the positive battery cable (4).
- Secure positive battery cable (4) at the clamp (5).
- Tighten the nut (3) hand-tight.

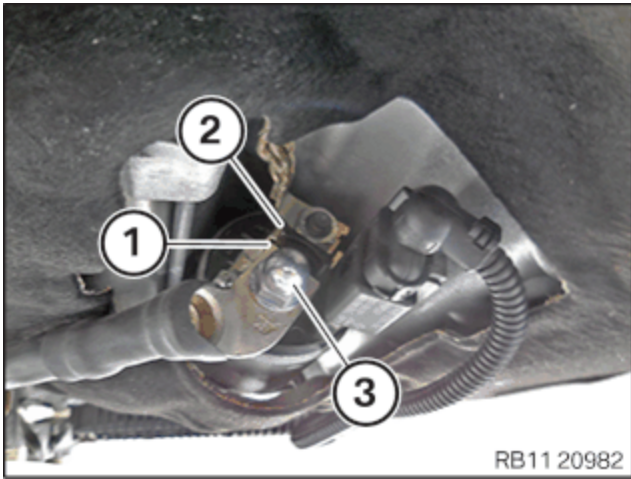

### Improper routing of the positive battery cable.

#### Risk of shorting!

- Route the positive battery cable without abrasions and do not trap.

- Attach the positive battery cable (1) **correctly** to anti-twist lock (2).
- Tighten nut (3).

### Positive battery cable to starter motor

M8	Tightening torque	13.5 Nm
----	-------------------	---------

## 47 – Install front axle

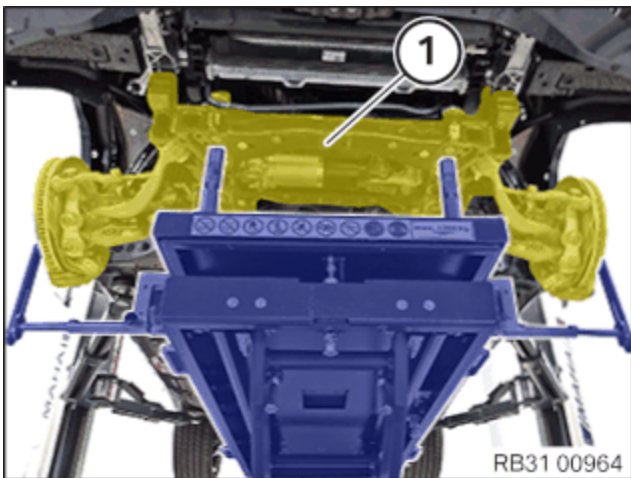

### Insufficient freedom of movement for adjacent components.

#### Damage to adjacent components.

- When lowering or lifting the subframe, ensure freedom of movement of the adjacent components.
- Lift the front axle (1) using the mobile lifting table and position on the vehicle.

## 48 – Tighten the bolts on the front axle support

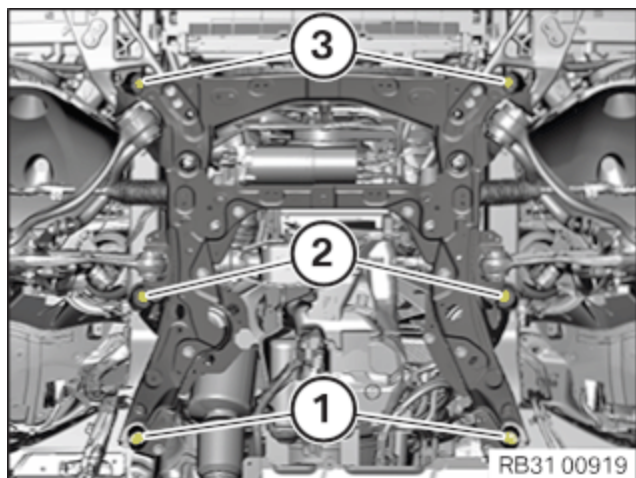

- Renew screws (1) to (3).

**Parts:** Screws, front

**Parts:** Screws, centre

**Parts:** Rear screws

- Tighten the screws (1).

### Front axle carrier to body, rear

M14	Renew screw.	Jointing torque	100 Nm
		Angle of rotation	90 °

- Tighten the screws (2).

### Front axle support to centre of body

M12	Renew screw.	Tightening torque	100 Nm
		Angle of rotation	90 °

- Tighten the screws (3).

### Front axle carrier to body, front

M12	Renew screw.	Jointing torque	100 Nm
		Angle of rotation	90 °

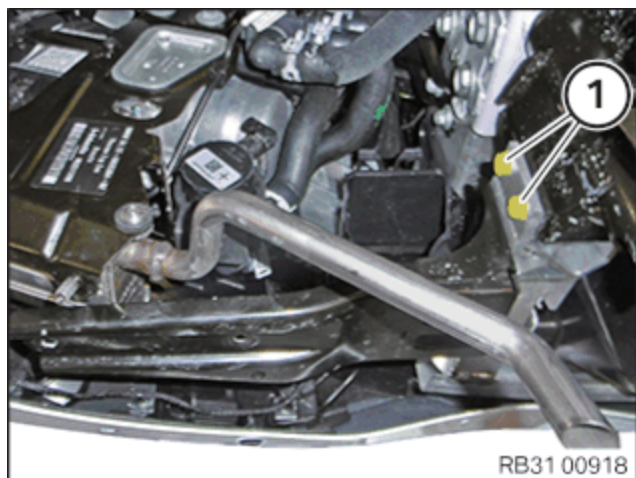

Perform the steps on the left and right side.

- Renew screws (1).

**Parts:** Screws

- Tighten the screws (1).

### Bottom bumper support on front axle support

M8	Renew screws.	Tightening torque	19 Nm
----	---------------	-------------------	-------

## 49 – Secure the wishbone on the top left and right on the swivel bearing



Perform the steps on the left and right side.

- Renew the screw and nut on the right.

**Parts:** Screw

**Parts:** Nut

### ► Mounting the control arm at top in the swivel bearing

- Position the journal of the top wishbone (3) in the bore hole of the swivel bearing (4).
- Renew screw (2) and nut (1).

**Parts:** Nut

**Parts:** Screw

- Insert the screw (2).
- Tighten nut (1).

#### Top control arm to swivel bearing

M10	Renew screw and nut.	Tightening torque	56 Nm
-----	----------------------	-------------------	-------

- Remove the special tool to fasten the swivel bearing.

## 50 – Removing the mobile lifting table

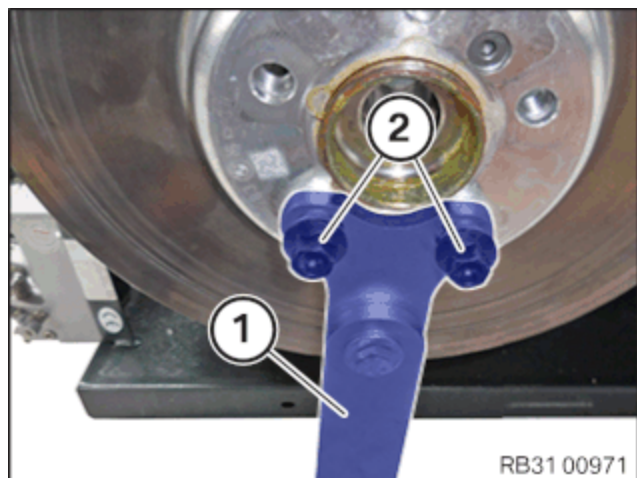

Perform the steps on the left and right side.

- Release the wheel bolts (2) at the mount (1).

- Disconnect the special tool **2 184 136** and/or **5 A16 8C6** and set aside.

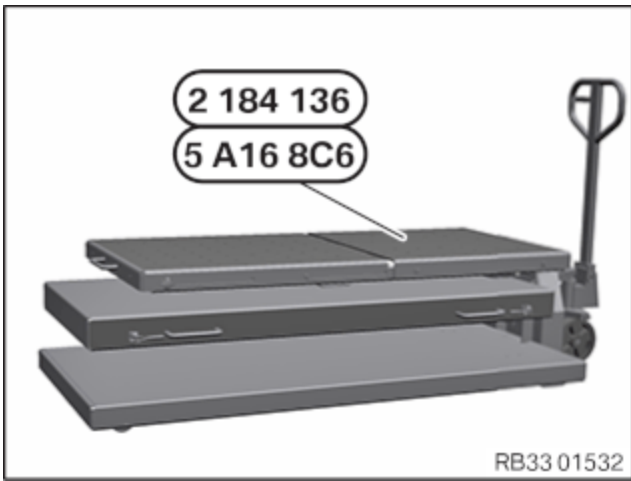

## 51 – Attaching coolant hoses to front axle support



The following step(s) is/are to be carried out if the specified component(s) is/are fitted.

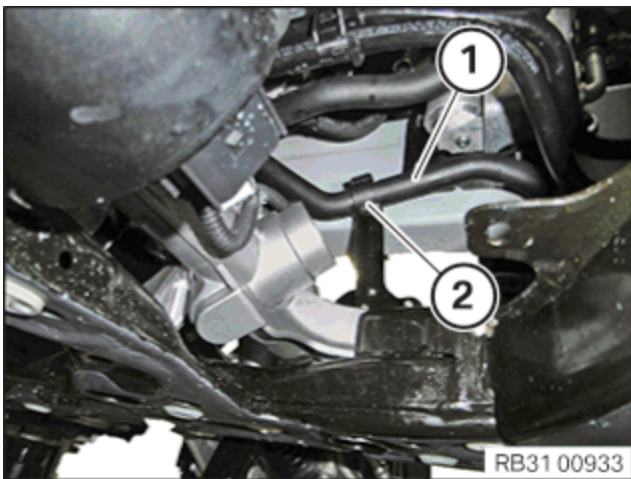

- Secure the coolant hose (1) at the bracket (2).

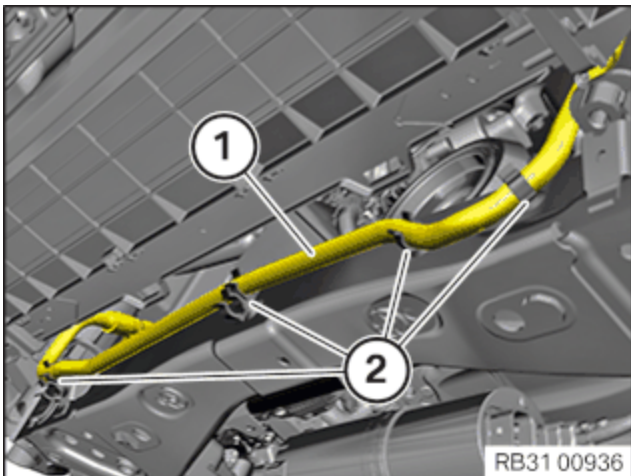

- Fasten the coolant hose (1) to the brackets (2).

- Fasten the coolant hose (1) to the holder (2).

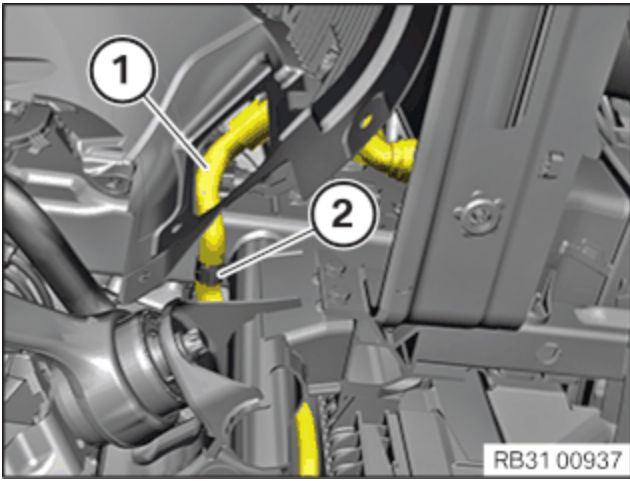

## 52 – Securing left and right spring strut holder to lower wishbone



Perform the steps on the left and right side.

- Renew the bolt and the nut.

**Parts:** Screw

**Parts:** Nut

### ► Securing the spring strut holder on the bottom wishbone

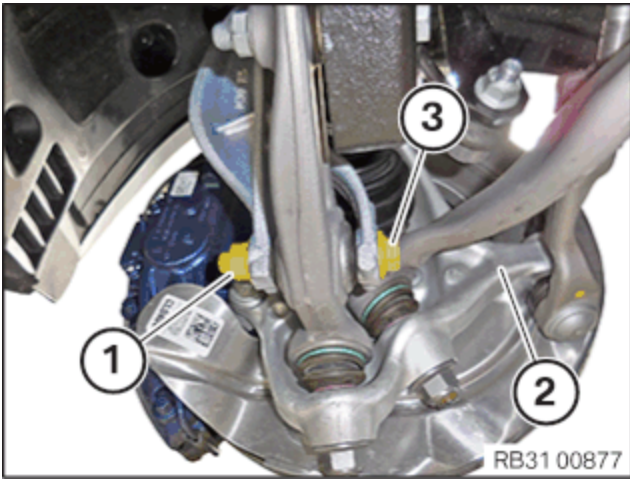

**i**

Tighten the screw connection in the normal position.

For additional information see: 31 00 Overview of Technical Data

- Position spring strut holder on the bottom wishbone.
- Renew screw (3) and nut (1).

**Parts:** Screw

**Parts:** Nut

- Punch in the swivel bearing (2) at the front in an inward direction.
- Insert the screw (3).
- Tighten the nut (1) in normal position.

#### Spring strut holder to lower wishbone

M14	Renew screw and nut.	Joining torque	165 Nm
	Tighten in normal position.	Angle of rotation	90 °

## 53 – Securing the brake calipers at left and right



Perform the steps on the left and right side.

- Renew screws.

**Parts:** Screw

### ► Securing the brake caliper



After a brake pad exchange and before actuating the brake pedal: Actuating the electromechanical parking brake is mandatory.

In case of non-compliance, a CC message appears and the brake system switches to the emergency program. The brake power assistance is no longer active.



Secure component against falling.

- Release and remove special tool **2 413 317**.

**Note:** Do not allow the brake caliper (1) to hang from the brake hose.

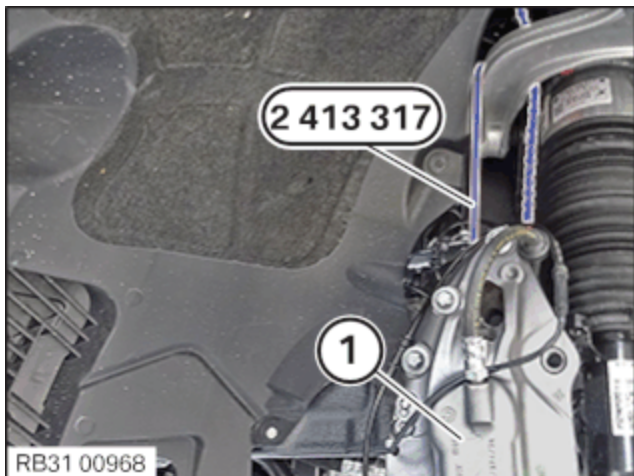

- Position the brake caliper (2) on the swivel bearing.
- Renew screws (1).

**Parts:** Screw

- Tighten the screws (1).

#### Brake calliper/calliper carrier to front swivel bearing

M12	Renew screw.	Tightening torque	130 Nm
-----	--------------	-------------------	--------

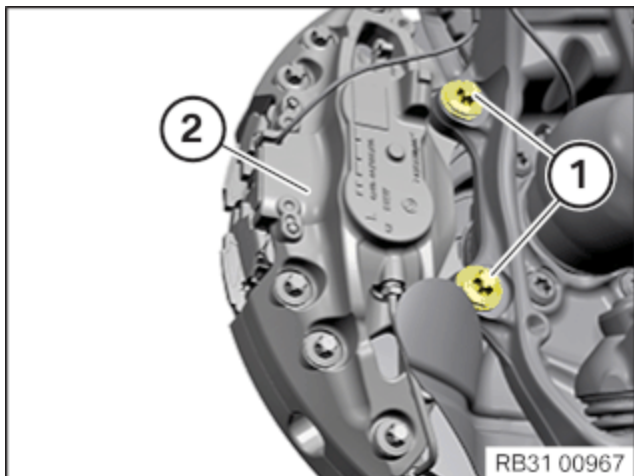

- Attach the cable (2) on the holder (3).
- **Left only:** Attach the cable (1) on the holder (3).

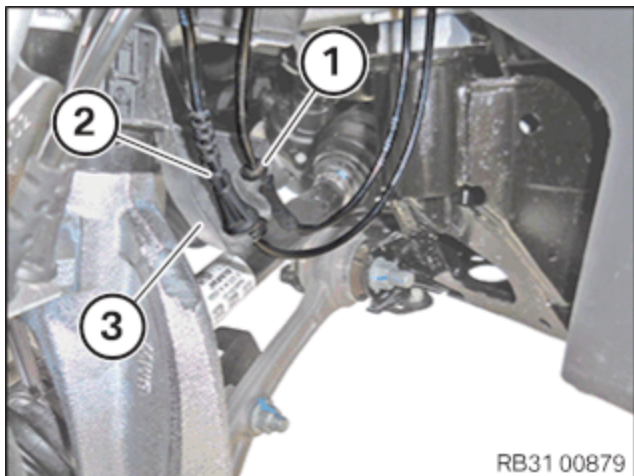

- Secure brake hose (1) on holders (2).

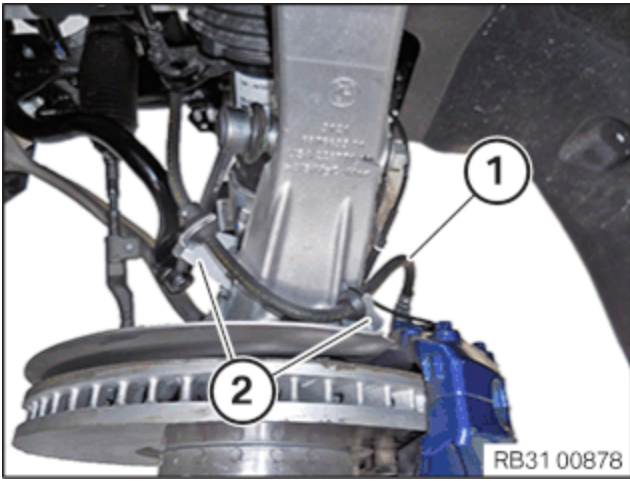

## 54 – Connect the connector on the left and right

### ► Connect the left-hand connector

- Secure cable at the holder (arrows).
- Connect connectors (2) and (3) lock.
- Close lid (1).

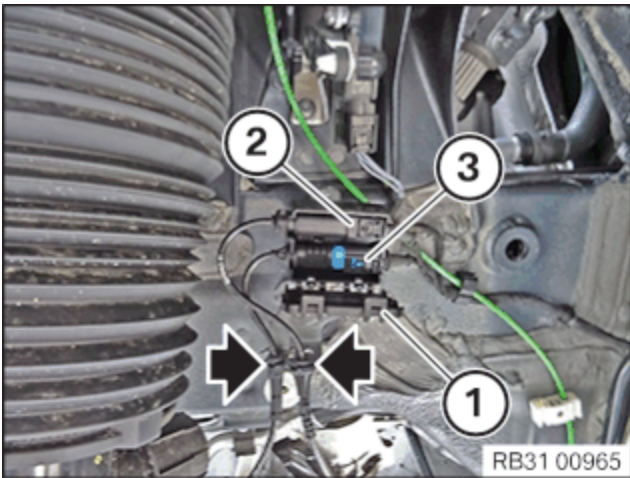

### ► Connect right-hand plug connection

- Secure cable to the holder (arrow).
- Connect connectors (2) and lock.
- Close lid (1).

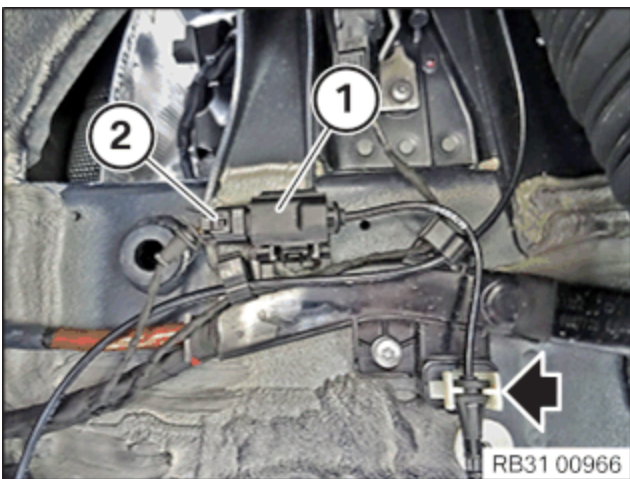

## 55 – Connecting the connector with the left and right vertical acceleration sensor



Description is for left component only. Procedure on the right side is identical.

### ► Connecting the connector to the vertical acceleration sensor



The following step(s) is/are to be carried out if the specified component(s) is/are fitted.

- Fasten the cable at the clips (2).
- Connect connectors (1) and lock.

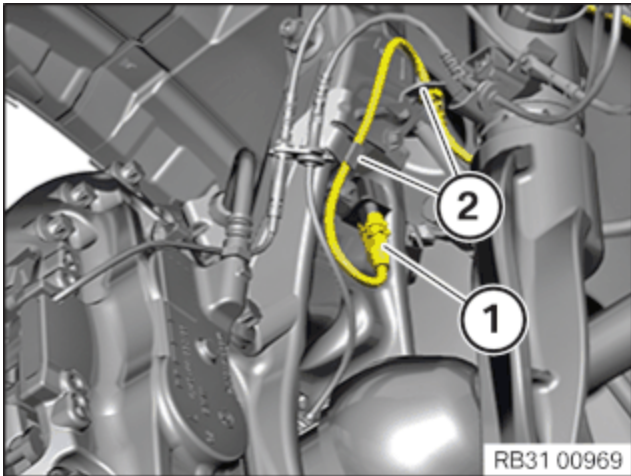

## 56 – Securing the universal joint on the steering gear



The universal joint can only be mounted in one position.

The universal joint and the steering gear or the steering shaft respectively are encoded to each other.

The clamping bolt must be positioned in the groove of the steering gear or the steering shaft.

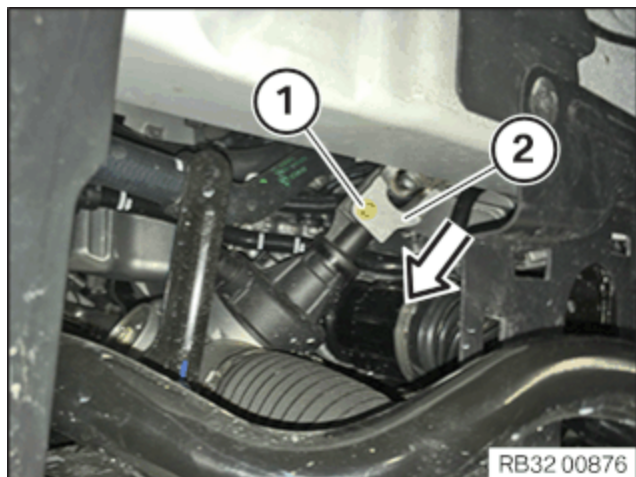

- Clean the screw threads to remove all remnants of screw locking adhesive.
- Slide the universal joint (2) onto the steering gear in the direction of the arrow.
- Renew the clamping bolt (1).

**Parts:** Clamping bolt

- Tighten screw (1).

### Universal joint to steering gear

M8	Recut screw thread. Renew clamping bolt.	Tightening torque	28 Nm
	No retorquing permitted!		

## 57 – Secure wiring harness on the active stabiliser (additional work FRU no.: 37 11 999)



The following step(s) is/are to be carried out if the specified component(s) is/are fitted.

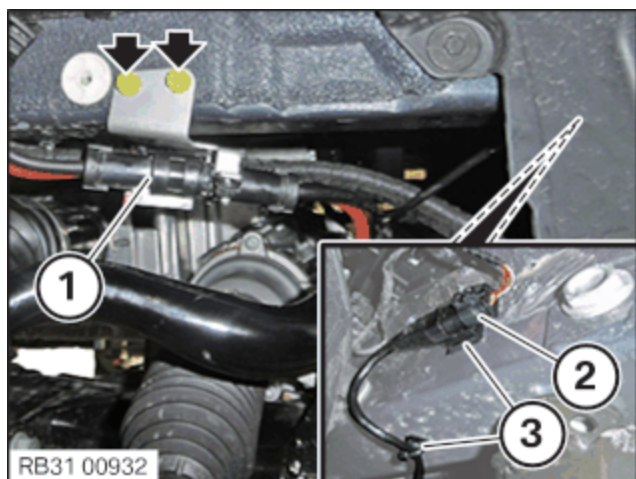

- Secure the cable with the holders (3) to the side member.
- Connect connectors (2) and lock.
- Renew the screws (arrows).

**Parts:** Screws

- Tighten screws (arrows).

### Connector holder for active stabilizer on side member

M6	Renew screw.	Tightening torque	5,8 Nm
----	--------------	-------------------	--------

- Connect connectors (1) and lock.

### 58 – Securing the wiring harness of the EPS

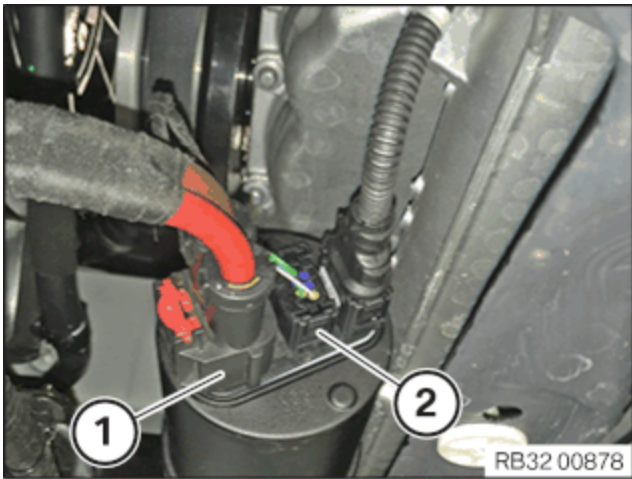

- Position wiring harness.
- Connect connectors (1) and (2) and lock.

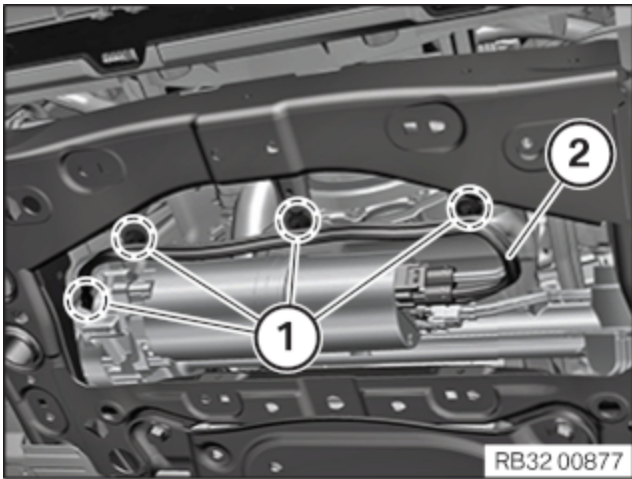

- Secure the vehicle wiring harness (2) on the brackets (1).

### 59 – If installed: Install the independent heater (additional work flat rate unit no.: 31 11 905)

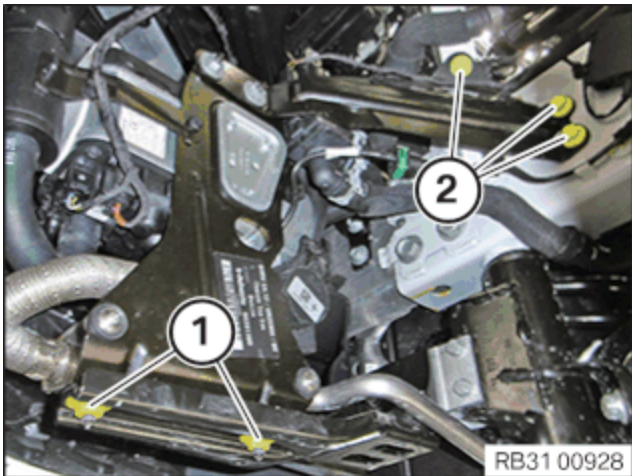

- Position the stationary heating system.
- Tighten the screws (2).

#### Bracket to body

M8	Tightening torque	19 Nm
----	-------------------	-------

- Tighten nuts (1).

#### Stationary heating system on holder

M8	Tightening torque	19 Nm
----	-------------------	-------

► Install the front section of the front wheel arch cover



To provide a better overview: Schematic diagram with partially hidden components.

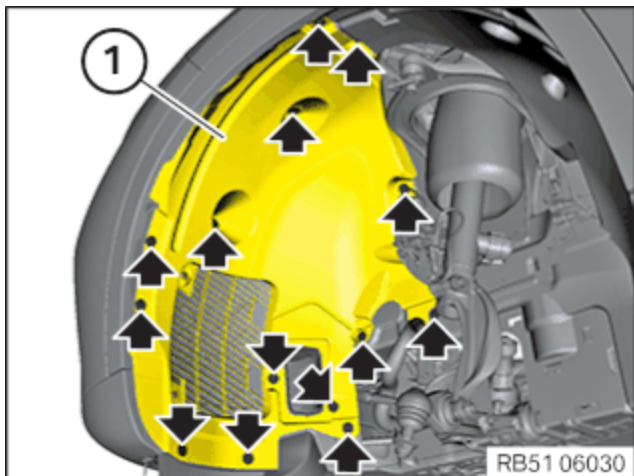

- Thread in front section of the wheel arch cover (1).
- Tighten screws (arrows).

#### Wheel arch cover

Thermoplastic hexagon screw	Tightening torque	2,6 Nm
Plastic nut	Tightening torque	2,6 Nm

## 60 – Installing left and right brake air duct



Perform the steps on the left and right side.

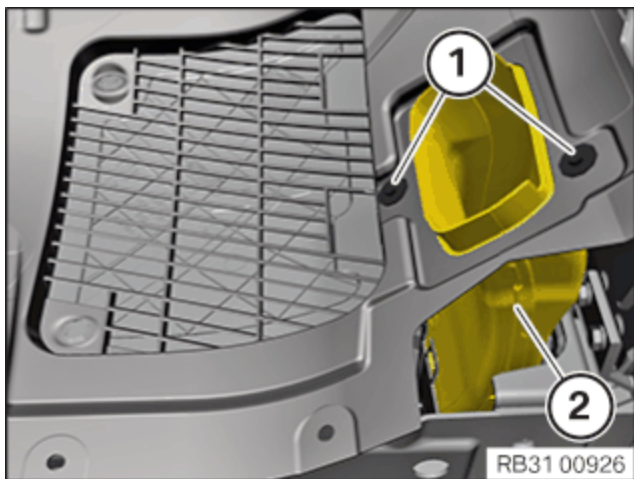

#### ► Install the brake air duct

- Guide in and position brake air duct (2).
- Tighten the screws (1).

#### Wheel arch cover

Thermoplastic hexagon screw	Tightening torque	2,6 Nm
Plastic nut	Tightening torque	2,6 Nm

## 61 – Install the left-hand and right-hand crash lever



Perform the steps on the left and right side.

- Renew the right screws.

**Parts:** Screws

### ► Installing crash lever



The following step(s) is/are to be carried out if the specified component(s) is/are fitted.

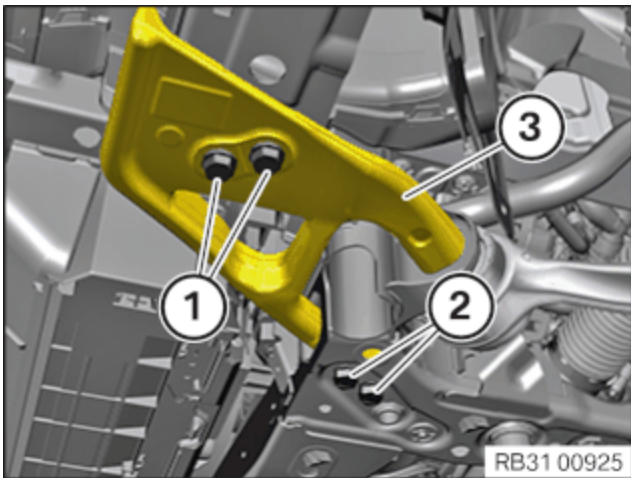

Left and right must not be mixed up!

- Position crash lever (3).
- Renew screws (1) and (2).

**Parts:** Screws

- Tighten screws (1) and (2).

### Crash lever on front axle support/frame

M12	Renew screw.	Tightening torque	68 Nm
-----	--------------	-------------------	-------

## 62 – Removing the engine from the installation position

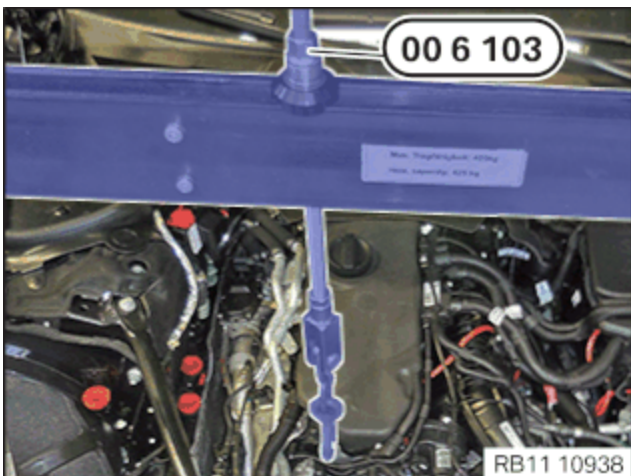

- Lower engine by turning the spindle **2 361 506 (00 6 103)** until the engine rests completely on the engine supports.

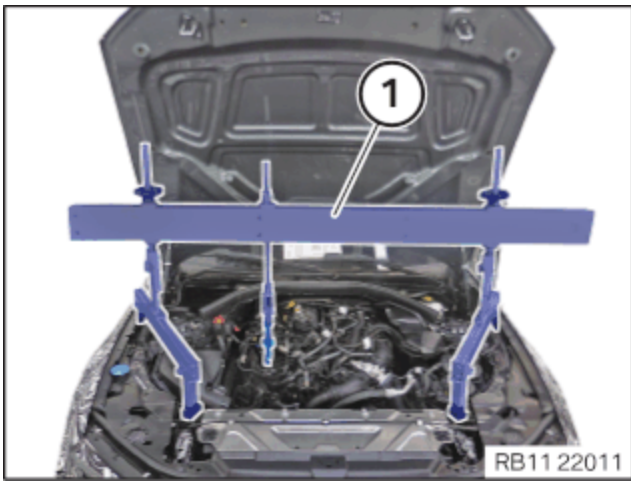

Schematic diagram is for example purposes. Some parts may differ in certain details.



Conduct the following step with the assistance of an auxiliary person.

- Remove the engine bridge (1) with an auxiliary person.



Conduct the following step with the assistance of an auxiliary person.



- Guide out and remove special tools and carefully.
- Remove the engine bridges.

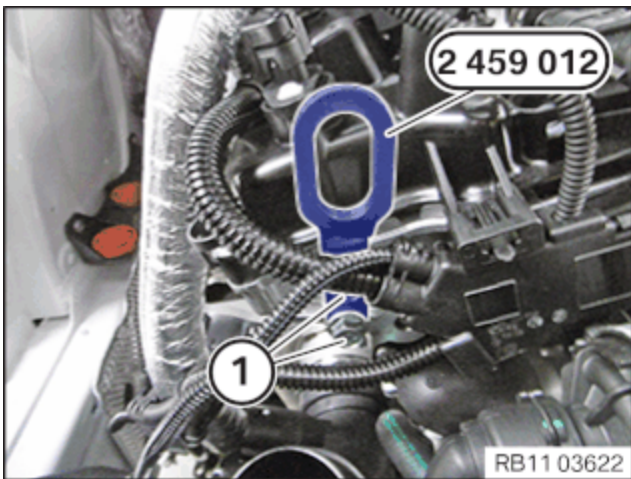

- Unscrew the bolts (1) of the special tool **2 459 012**.
- Guide the special tool **2 459 012** out and remove.

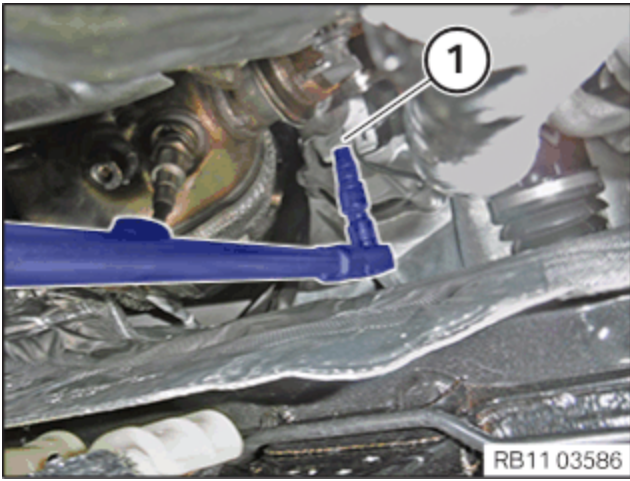

- Tighten screw (1) of the right engine mount from above with a standard tool.

#### Engine mount to engine mounting bracket

M12	Renew the screw and clean the thread on the engine mount.	Tightening torque	110 Nm
-----	---	-------------------	--------

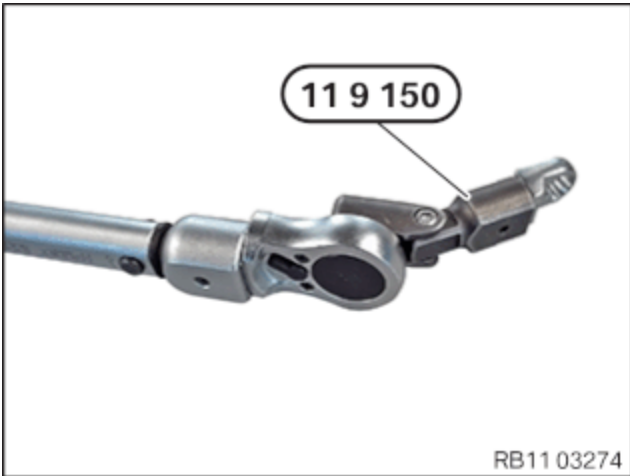

- Prepare special tool **0 493 751 (11 9 150)** as shown.

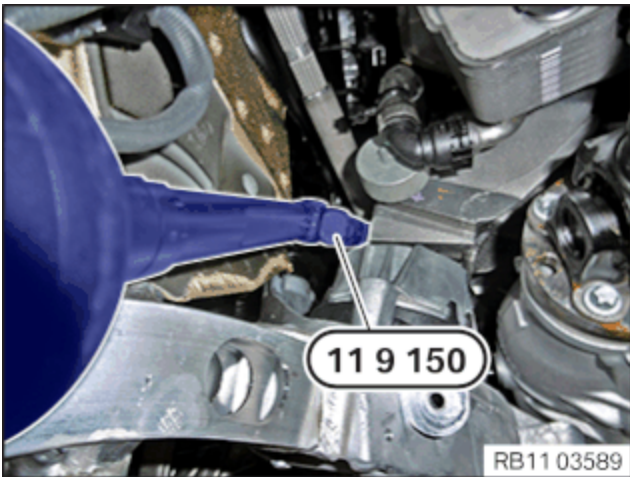

- Tighten screw of the left engine mount from below with special tool **0 493 751 (11 9 150)**.

#### Engine mount to engine mounting bracket

M12	Renew the screw and clean the thread on the engine mount.	Tightening torque	110 Nm
-----	---	-------------------	--------

- Install the bracing strut (2).
- Tighten down screw (1).

#### Engine mount bracing strut on front axle support

M12x25	Tightening torque	108 Nm
--------	-------------------	--------

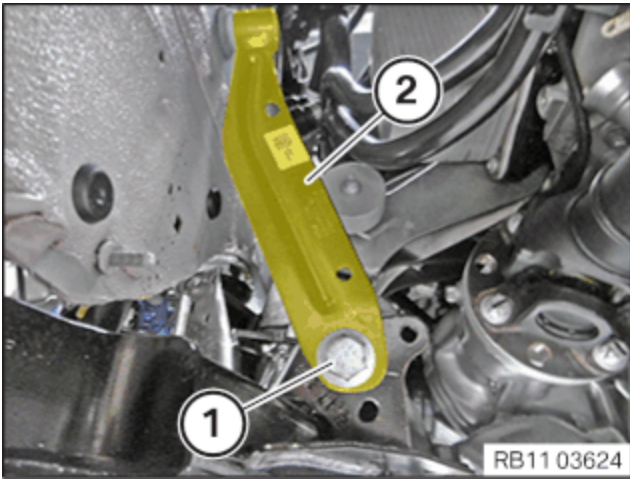

- Tighten down screw (1).

#### Engine mount bracing strut on body

M12x120	Tightening torque	108 Nm
---------	-------------------	--------

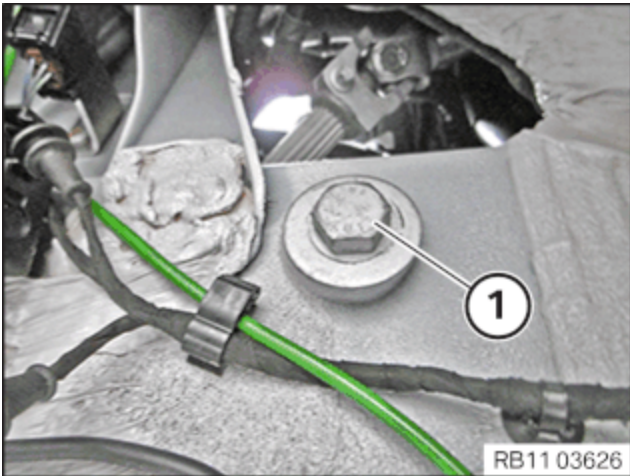

### 63 – Installing the right bracing strut

- Position the bracing strut (2).
- Pilot the screw (1) on the front axle carrier.

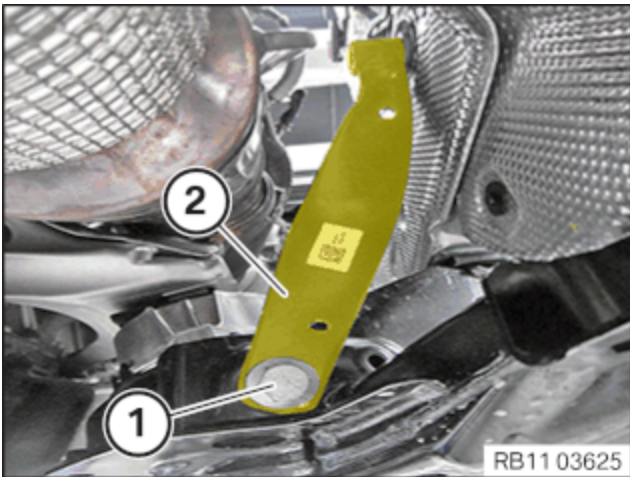

- Pilot and tighten screw (1).

### Bracing strut on engine support

M12x120	Tightening torque	108 Nm
---------	-------------------	--------

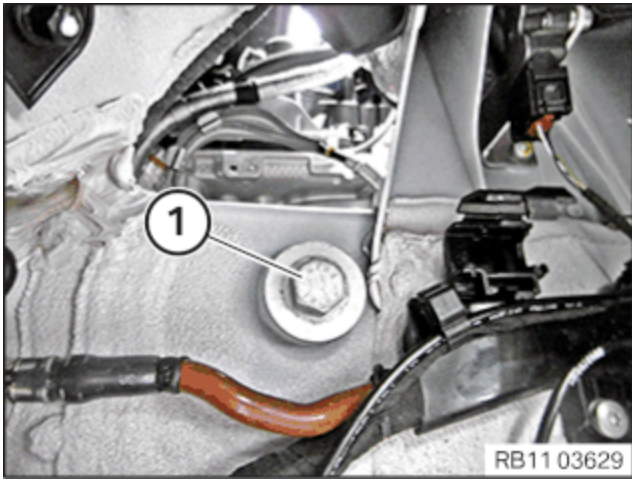

- Tighten the screw (1) at the bracing strut (2).

### Bracing strut on front axle support

M12x25	Tightening torque	108 Nm
--------	-------------------	--------

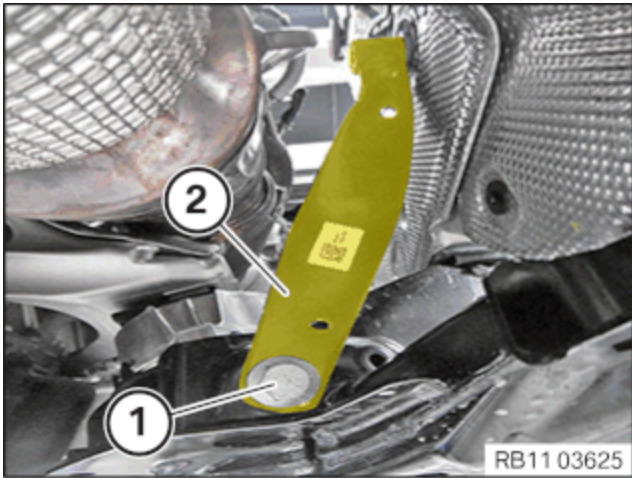

## 64 – Remove wheel house covering from the bottom left and right on the front end



Perform the steps on the left and right side.

### ► Installing the front bottom wheel arch cover

- Guide the bottom front wheel arch cover (1) in.
- Tighten all bolts (arrows).

### Wheel arch cover, bottom front

Thermoplastic hexagon screw	Tightening torque	2.6 Nm
-----------------------------	-------------------	--------

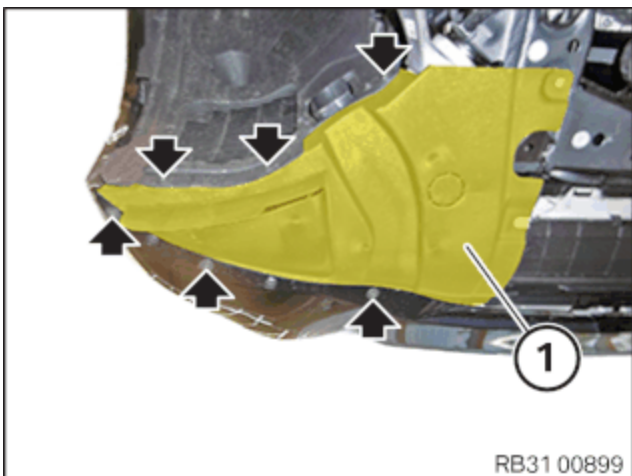

## 65 – Install the rear section of the front wheel arch cover on the left and right



Description is for left component only. Procedure on the right side is identical.

### ► Installing the rear section of the front wheel arch cover



To provide a better overview: Schematic diagram with partially hidden components.

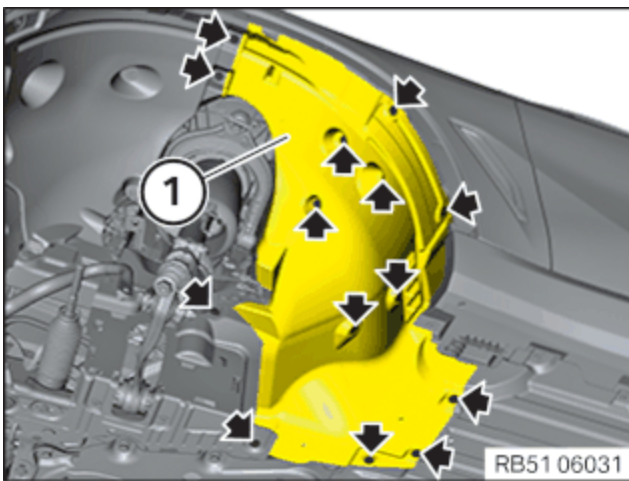

- Manoeuvre the rear section (1) of the wheel arch cover into place.
- Tighten screws (arrows).

#### Wheel arch cover

Thermoplastic hexagon screw	Tightening torque	2,6 Nm
Plastic nut	Tightening torque	2,6 Nm

## 66 – Install the cover of the steering assembly on the left and right



Perform the steps on the left and right side.

### ► Install the cover of the steering assembly



To provide a better overview: Schematic diagram with partially hidden components.

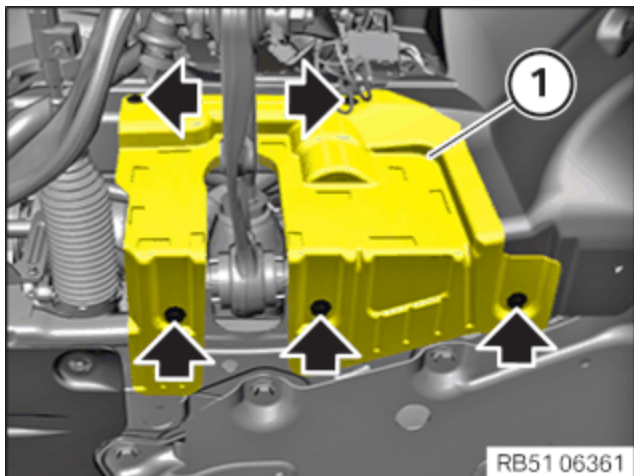

- Insert the cover (1).
- Tighten all bolts (arrows).

#### Steering assembly cover

Thermoplastic  
hexagon bolt

Tightening  
torque

2.6 Nm

### 67 – Installing wheel arch trim at the front side sill left and right (partially removed)



Perform the steps on the left and right side.

#### ► Install front wheel arch trim on the side sill (partially removed)

##### • G05/G18/F95:

Check clips (2) for damage, replace if necessary.

Check the sealing ring for damage and renew where required.

The sealing ring must not be damaged or missing.

Position the wheel arch trim (1) and engage at the clips (2).

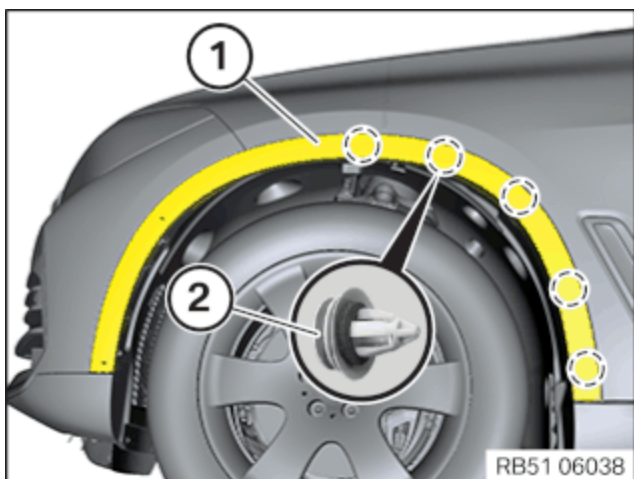

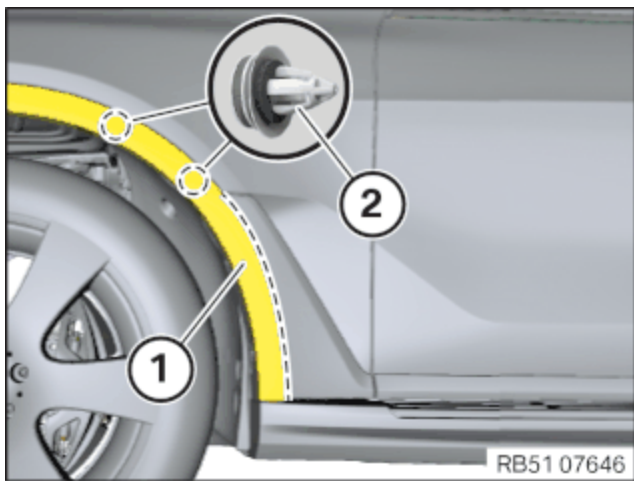

- **G06/G07:**

Check clips (2) and the sealing ring for damage, renew if necessary.

The sealing ring must not be damaged or missing.

Check locks for damage and, if necessary, renew the wheel arch trim (1).

Position the wheel arch trim (1) and engage at the clips (2).

Engage wheel arch trim (1) to the latch mechanisms along the dotted line.

## 68 – Mounting the front left and right wheels



Perform the steps on the left and right side.

### ► Mounting the wheel

#### ▷ Cleaning the contact surfaces between the brake disc and the wheel rim



The contact surface between the brake disc and the wheel rim must be clean and free from oil and grease. There is otherwise a risk of the wheel becoming loose at a later time.

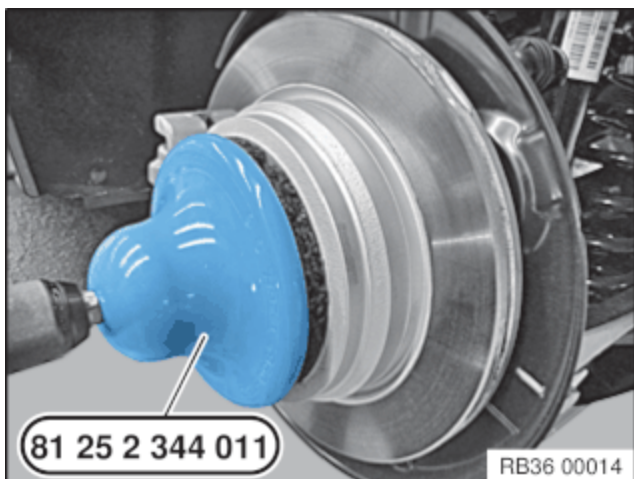

- Remove dirt, grease residues and corrosion from the contact surface with a drill and the special tool **2 344 011**.

Do not operate special tool **2 344 011** with an impact screwdriver.

- Degrease the contact surfaces with the universal cleaner (see BMW Group parts sales and distribution).
- If there are grease residues in the area of the wheel bolt holes, remove and clean the brake disc.

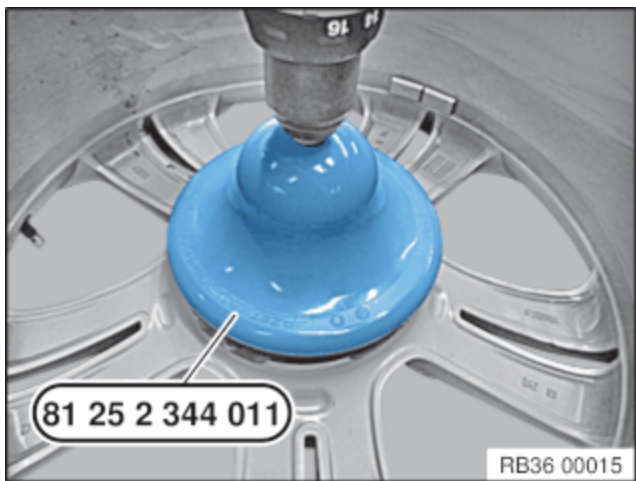

- Remove dirt, grease residues and corrosion from the contact surface with a drill and the special tool **2 344 011**.

Do not operate special tool **2 344 011** with an impact screwdriver.

- Degrease the contact surfaces with the universal cleaner (see BMW Group parts sales and distribution).

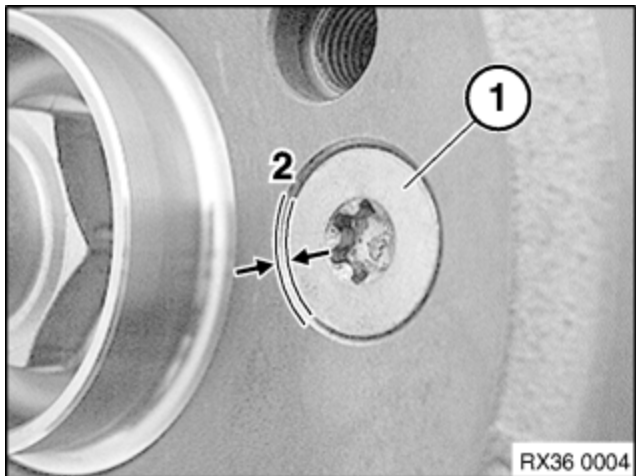

- Check that the mounting bolt (1) for the brake disc is securely fitted.

The mounting bolt (1) for the brake disc may **not** protrude on the contact surface (2) between the brake disc and the wheel rim.

**Brake disc to front wheel hub**

M8	Tightening torque	16 Nm
----	-------------------	-------

**Brake disc to rear wheel hub**

M8	Tightening torque	16 Nm
----	-------------------	-------

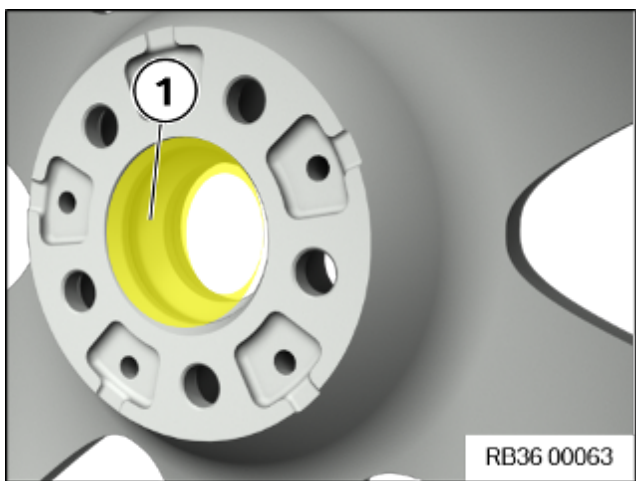

- Thinly grease the wheel centring (1) in the wheel rim.

**Expendable materials**

Brake pad paste	3 g,	83192158851
* TU = Trade Unit. TU numbers cannot be ordered! For invoicing purposes only.	Bag	
	100 g,	83192158852
	Tube	
	5 g,	83230140233
	TU*	

- Lightly grease the front and rear wheel hubs in this area (1) to protect from corrosion.

**Expendable materials**

Brake pad paste	3 g, Bag	83192158851
* TU = Trade Unit. TU numbers cannot be ordered! For invoicing purposes only.	100 g, Tube	83192158852
	5 g, TU*	83230140233

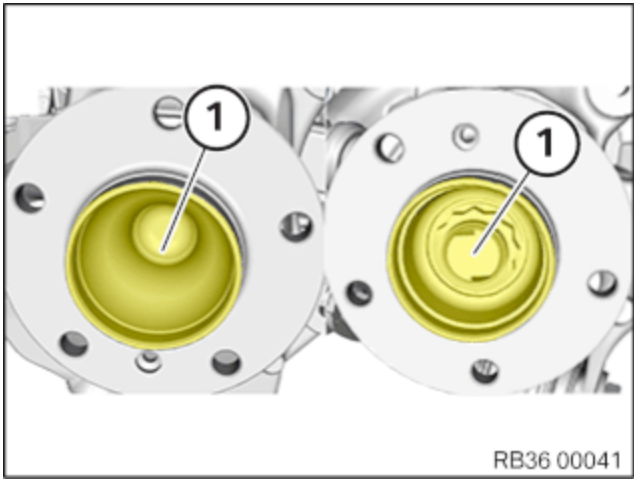

- In vehicles with carbon ceramic brake: The wheel lift must be used to install the wheel (see workshop equipment).

This process is intended to prevent damage to the brake disc.



**Check**

- Check wheel bolts for wear.

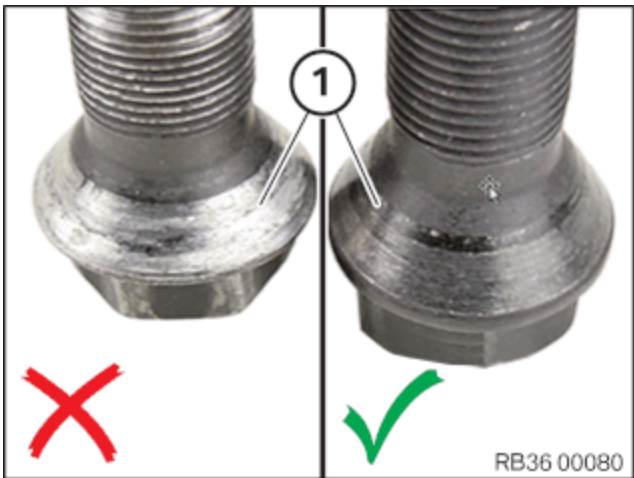

### Result

» Places (> 30%) of the bearing surface (1) of the taper on the screw head show a silver wear.

### Measure

- Replace wheel bolts.



A wheel lift is recommended for easier wheel removal and installation without exertion (see Retailer Equipment Catalogue).

- Provide wheel lift.





## i

Never use impact screwdrivers or electric screwdrivers to screw in and tighten the wheel bolts.

The wheel rim must rest uniformly against the brake disc.

In the case of non-original BMW wheel bolts/wheel rims, it may be necessary to retighten the wheel bolts on account of setting properties (refer to the documentation from the manufacturer).

Do not apply oil to new wheel bolts.

Recutting a damaged thread (wheel bolt/wheel hub) is not permissible!

- Renew corroded wheel bolts (arrows).
- Clean the wheel bolts (arrows).
- Check the wheel bolts (arrows) and threads for damage, renew the wheel bolts (arrows), if necessary.
- Position and tighten the wheel bolts (arrows).

### Wheel bolts

M	Screw in wheel bolts and evenly	Tightening torque	140 Nm
14/width across flats 17	apply crosswise by hand to centre the wheel rim.		
	Tighten wheel bolts crosswise to the specified tightening torque with a calibrated torque wrench.	Check	140 Nm
	Check all wheel bolts in the same order or retighten to the specified tightening torque again.		

## 69 – Install the cover in the engine compartment at top left and right

### ► Installing the cover in the engine compartment on top

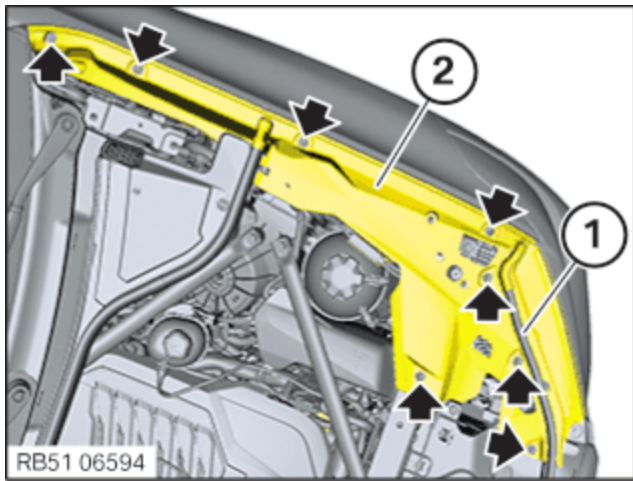

- Feed in cover (2) and position correctly.
- Clip in the bonnet seal (1) in the area of the cover (2) at the clips.
- Mount the expanding rivets (arrows).

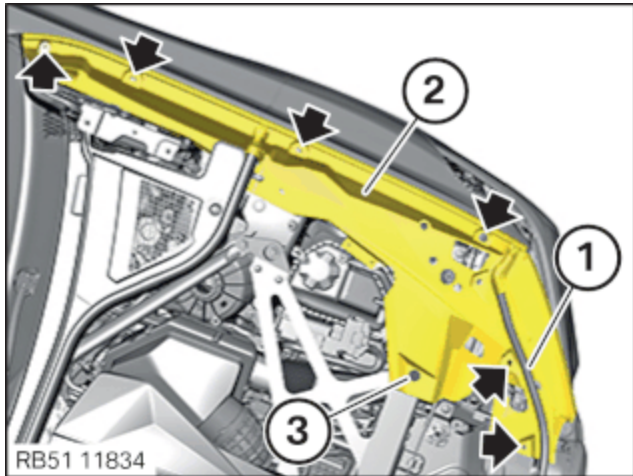

- **Only for F95/F96 LCI vehicles:**
- Feed in cover (2) and position correctly.
- Clip in the bonnet seal (1) in the area of the cover (2) at the clips.
- Mount the expanding rivets (arrows).
- Tighten the screw (3).

### ► Install the cover in the engine compartment on the top right

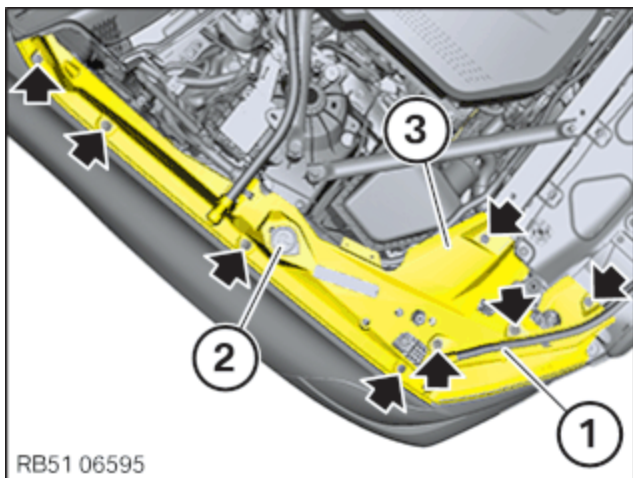

- Feed in cover (3) and position correctly.
- Mount the expanding rivets (arrows).
- Clip in the bonnet seal (1) in the area of the cover (3) at the clips.
- Mount the lid (2) of the washer fluid reservoir .

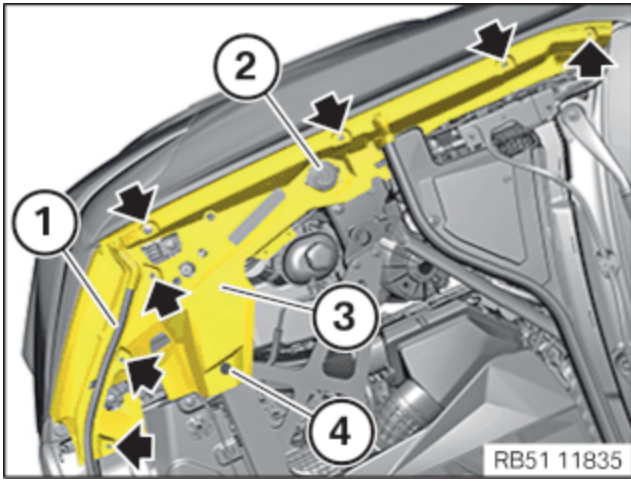

- **Only for F95/F96 LCI vehicles:**
- Insert cover (3) and position correctly.
- Clip in the bonnet seal (1) in the area of the cover (2) at the clips.
- Mount the expanding rivets (arrows).
- Tighten the screw (4).
- Mount the lid (2) of the washer fluid reservoir .

## 70 – Installing the seal for the front bonnet

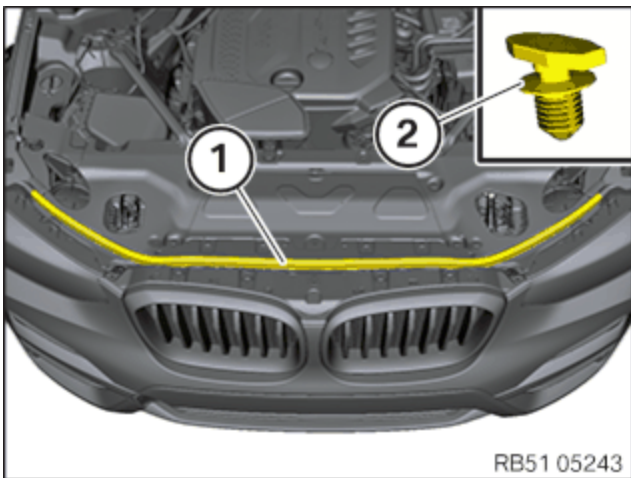

- Check the clips (2) for damage and presence. Damaged or missing clips (2) must be renewed.
- Remove the remaining clips (2) on the vehicle and attach them on the front bonnet seal (1).
- Install the front bonnet seal (1) and clip in it into the clips (2).

## 71 – Install acoustic cover



### Damage to the acoustic cover/design cover.

**Jerky movements during disassembly and excessive application of force during installation may result in breakage of the acoustic cover/design cover.**

- Disassemble or mount the acoustic cover/design cover carefully.
- Disassemble or mount snap-lock couplings of the taper spigots one after the other.
- Disassemble or mount acoustic cover/design cover only at temperatures > 20°C.
- Use only distilled water as an auxiliary material during installation, no lubricating materials.

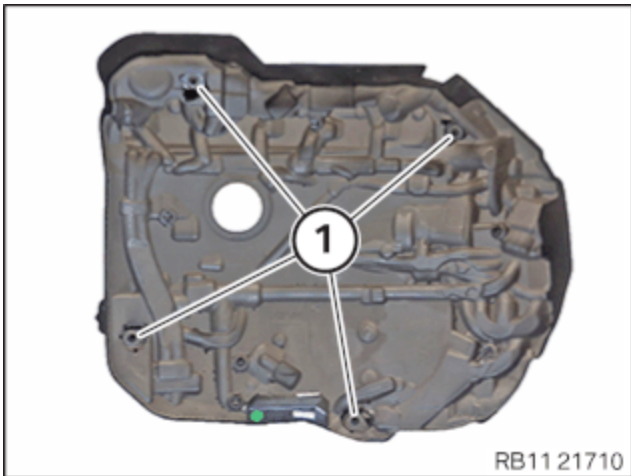

- Check the rubber mount (1) for correct fit in the acoustic cover.



- Install acoustic cover (1) and fix in the rubber mounts (marks).

## 72 – Filling the engine oil



### Damage to the petrol particulate filter.

**Vehicles equipped with a petrol particulate filter must be operated using low-ash engine oil only.**

- Only use engine oils approved by BMW for the respective engine.
- For additional information see: Overview of technically suitable engine oils for BMW Group engines.



### Engine damage caused by overfilling with engine oil.

**Overfilling with engine oil may cause engine damage.**

- Observe the exact engine oil capacity.
- Allow engine oil to drip off when draining.

- Pour in engine oil.

#### Engine oil B58B30M1/B58B30O1

Capacity, engine oil change with oil filter element, <b>B58B30M1rear-wheel drive</b>	6.50 l
--	--------

Capacity, engine oil change with oil filter element, <b>B58B30M1all-wheel drive</b>	6.50 l
---	--------

Capacity, engine oil change with oil filter element, <b>B58B30O1rear-wheel drive</b>	6.50 l
--	--------

Capacity, engine oil change with oil filter element, <b>B58B30O1all-wheel drive</b>	7.20 l
---	--------

Engine oil: Technically suitable engine oils for BMW Group engines

## 73 – Installing the oil filler cap

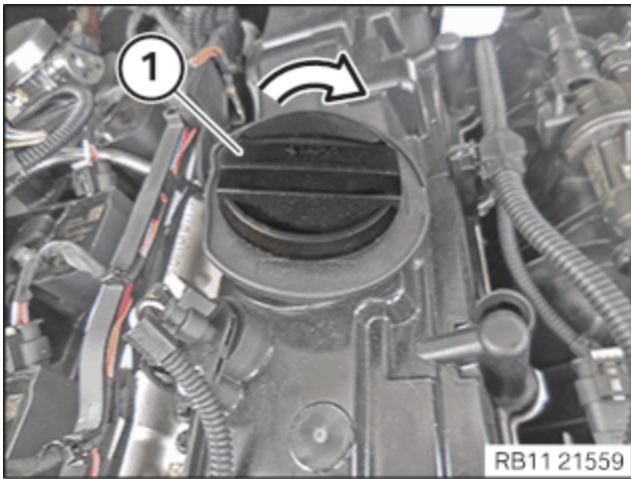

- Close oil filler cap (1) in the direction of the arrow.
- Ensure that the oil filler cap (1) engages audibly.

## 74 – Activate vehicle-specific high-voltage or low-voltage vehicle electrical system



It is mandatory to follow the vehicle-specific instructions given in the **further information!**

- Activate the electrical system in accordance with the specifications described in the additional information.

## 75 – Activating the 48V vehicle electrical system

### Prerequisite

Ignition is switched off.



### Damage to 48V battery

**If a 48V battery that is disconnected from the electrical system is activated, the battery electronics will be damaged.**

- Only carry out activation of the 48V vehicle electrical system with a completely connected 48V battery.

- Lift negative battery cable (1).
- Remove special tool .

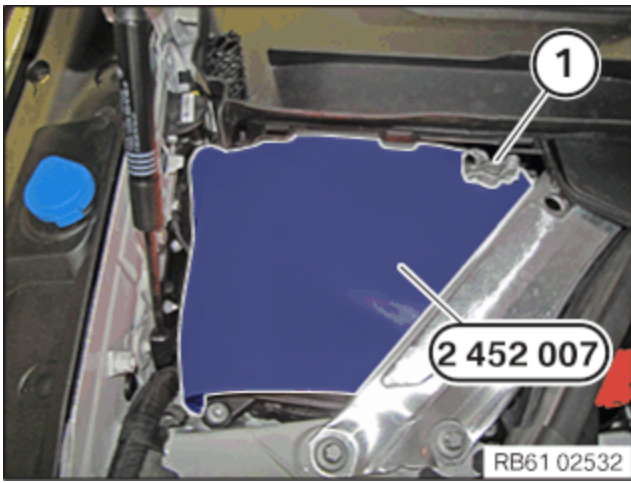

- Loosen the negative battery cable (2) of the 48V battery from the mounting.
- Position the negative battery cable (2) of the 48V battery on the negative battery terminal.
- Tighten nut (1).

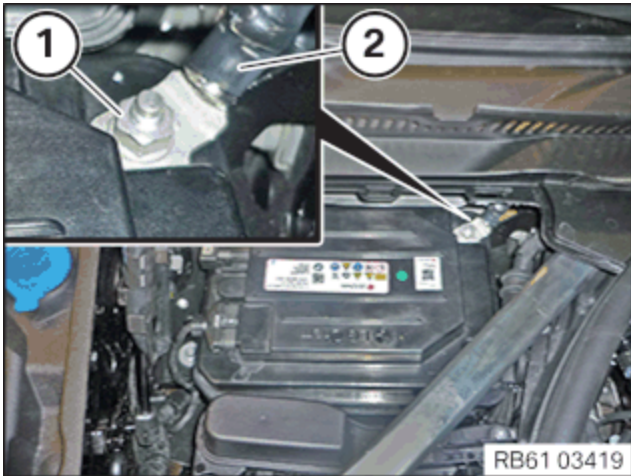

**Negative battery cable to 48V battery**

M8 nut	Threaded connections must be checked according to the four-eyes principle and documented in the vehicle records.	Tightening torque	19 Nm
--------	--	-------------------	-------

- Connect the connector (1) of the CAN bus and lock it.
- Clip in clip (2).

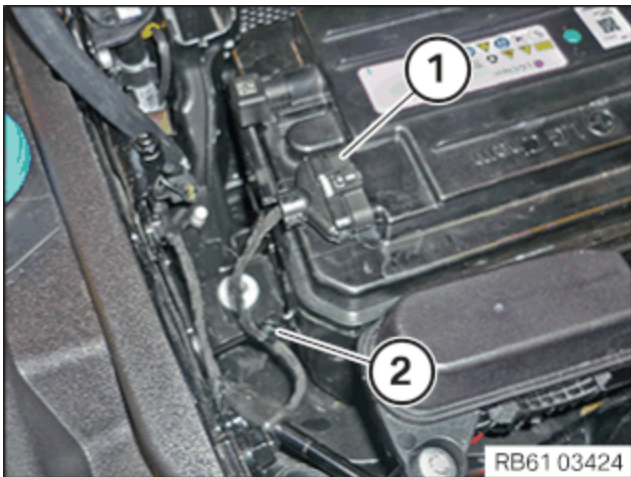



- Activate the 48V vehicle electrical system by closing the bonnet.

The activation takes place automatically.

## 76 – Checking the engine oil level

### Prerequisite

Vehicle in horizontal position.



Observe Owner's Handbook.

- Carry out an electronic oil measurement.
- Top up engine oil, if necessary.

## 76 – Pre-drive check oil level measurement

## 77 – Applying brake pads to brake disc/putting into operation



After a brake pad exchange and before actuating the brake pedal: Actuating the electromechanical parking brake is mandatory.

In case of non-compliance, a CC message appears and the brake system switches to the emergency program. The brake power assistance is no longer active.

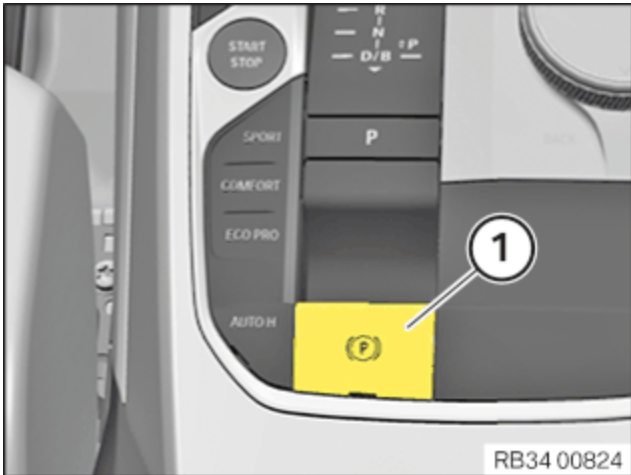

- Actuate/engage electromechanical parking brake (1).

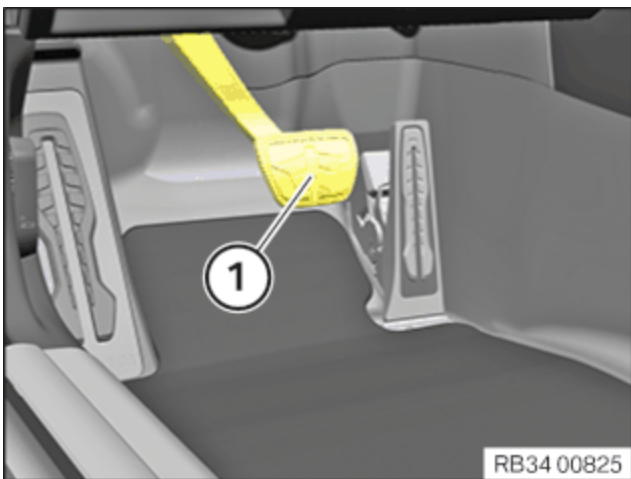

- Fully depress brake pedal (1) several times so that brake pads are in contact with the brake discs.

## 78 – Installing underbody protection at rear

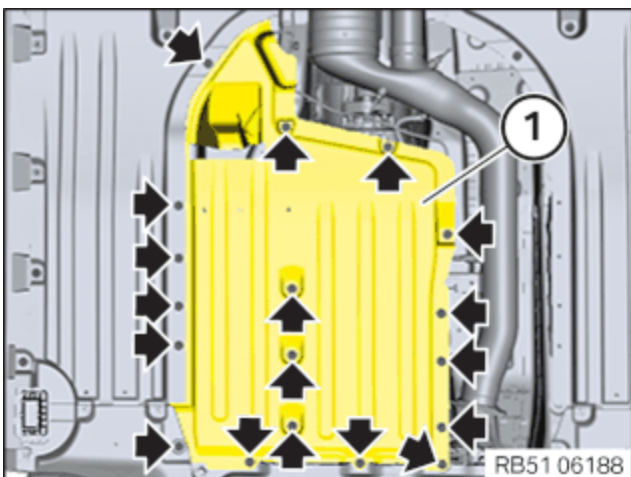

- Guide in underbody protection (1) and position it correctly.
- Tighten screws (arrows).

### Underbody panelling/frame

Hexagon  
screw

Tightening  
torque

3 Nm

## 79 – Installing the stiffening plate

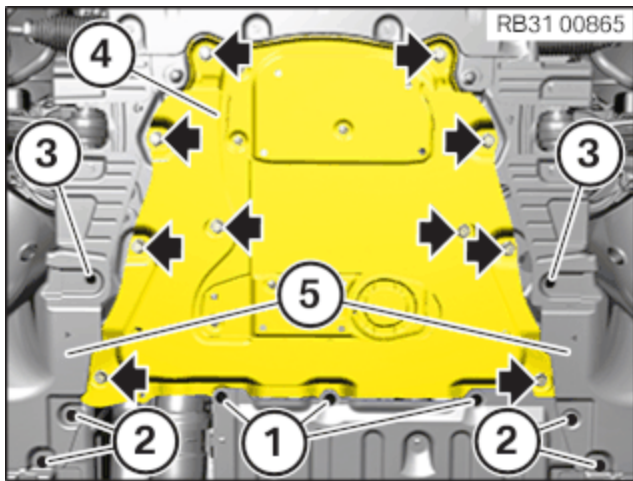

- Guide stiffening plate (4) into area (5) of the wheel arch trim panel and position it on the front axle support.
- Renew the screws (arrows).

### Parts: Screws

- Tighten screws (arrows).

### Stiffening plate to front axle support

M10	Renew screws.	Jointing torque	56 Nm
		Angle of rotation	90 °

- Tighten the screws (3).

### Steering assembly cover

Thermoplastic hexagon bolt	Tightening torque	2.6 Nm
----------------------------	-------------------	--------

- Tighten the screws (2).

### Wheel arch cover

Thermoplastic hexagon screw	Tightening torque	2,6 Nm
Plastic nut	Tightening torque	2,6 Nm

- Tighten the screws (1).

### Underbody panelling/frame

Hexagon screw	Tightening torque	3 Nm
---------------	-------------------	------

## 80 – Installing the front underbody protection



Different versions may be installed depending on the vehicle equipment.

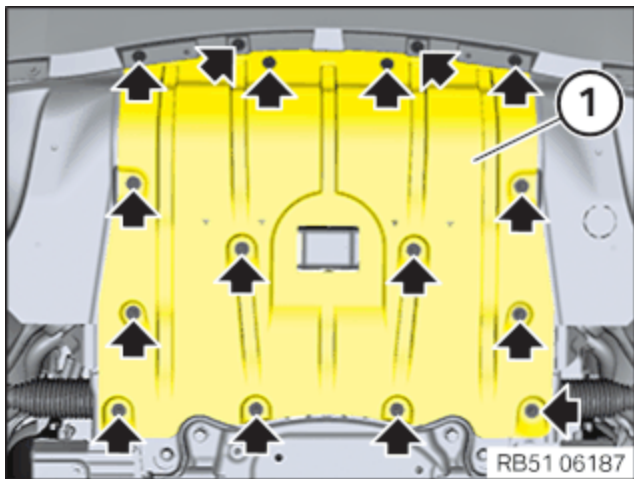

- Insert front underbody protection (1) and position correctly.
- Tighten screws (arrows).

### Underbody panelling/frame

Hexagon screw	Tightening torque	3 Nm
---------------	-------------------	------

## ► Installing the front underride protection



The following step(s) is/are to be carried out if the specified component(s) is/are fitted.

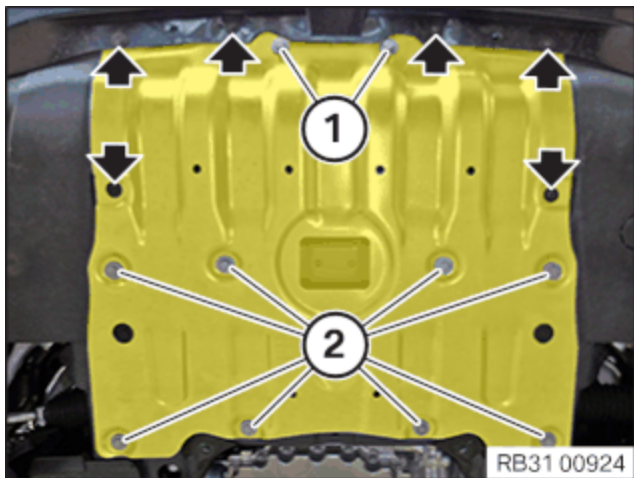

- Insert and position the front underride protection.
- Tighten down screws (2) and (1).

### Underride protection at the front to the front axle support

M8	Tightening torque	19 Nm
----	-------------------	-------

- Tighten screws (arrows).

### Underbody panelling/frame

Hexagon screw	Tightening torque	3 Nm
---------------	-------------------	------

## 81 – Taking the bonnet out of the service position



### Shutting bonnet or tailgate.

#### Danger of injury!

- Support bonnet/tailgate in fully open position with the aid of a suitable device.

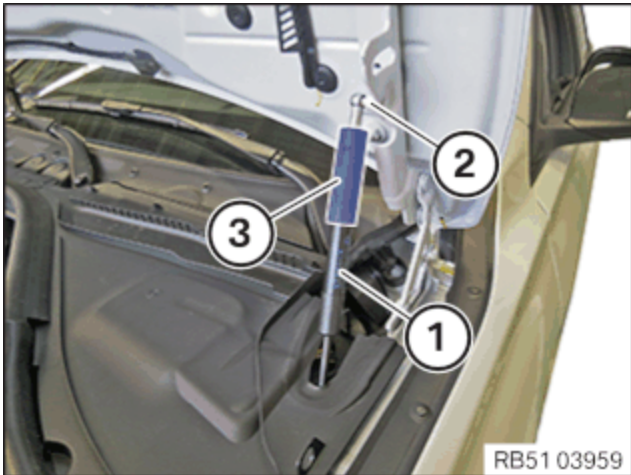

- Support the bonnet by hand.
- Remove the special tool (3) from the ball pin (2).
- Pull off the special tool (3) from the gas pressure spring (1).
- Continue to support the bonnet and repeat the step on the other side of the vehicle.

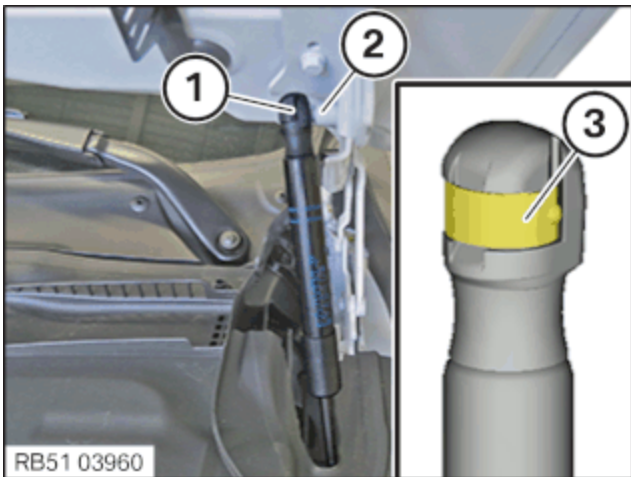

- Check the clamp (3) for correct fit.
- Connect ball socket (1) to ball pin (2).
- Continue to support the bonnet and repeat the step on the other side of the vehicle.

## Additional Information

### Overview of Tightening Torques

#### Oil drain plug

Used in step [17](#)

M12x16	Renew the sealing ring.	Tightening torque	25 Nm
--------	-------------------------	-------------------	-------

#### Special tool to cylinder head

Used in step [19](#)

M8		Tightening torque	21,5 Nm
----	--	-------------------	---------

<b>Sprocket to oil pump</b>			Used in step <a href="#">43</a>
M8	Important - left-hand thread Renew screw.	1. Tightening torque	5 Nm
		2. Angle of rotation	90 °
<b>Oil pump to crankcase</b>			Used in step <a href="#">43</a>
M8	Renew screw.	1. Jointing torque	15 Nm
		2. Angle of rotation	45 °
<b>Oil sump to crankcase</b>			Used in step <a href="#">44</a>
M8 x 30		Tightening torque	24 Nm
<b>Oil sump to crankcase</b>			Used in step <a href="#">44</a>
M8 x 110		Tightening torque	24 Nm
<b>Transmission to oil sump (manual transmission and automatic transmission)</b>			Used in step <a href="#">44</a>
M8 x 50		Tightening torque	19 Nm
<b>Starter motor to crankcase</b>			Used in step <a href="#">45</a>
M8x60		Tightening torque	19 Nm
<b>Holder for transmission oil line</b>			Used in step <a href="#">46</a>
Screw		Tightening torque	4 Nm
<b>Positive battery cable to starter motor</b>			Used in step <a href="#">46</a>
M8		Tightening torque	13.5 Nm
<b>Front axle carrier to body, rear</b>			Used in step <a href="#">48</a>
M14	Renew screw.	Jointing torque	100 Nm
		Angle of rotation	90 °
<b>Front axle support to centre of body</b>			Used in step <a href="#">48</a>
M12	Renew screw.	Tightening torque	100 Nm
		Angle of rotation	90 °
<b>Front axle carrier to body, front</b>			Used in step <a href="#">48</a>
M12	Renew screw.	Jointing torque	100 Nm
		Angle of rotation	90 °

<b>Bottom bumper support on front axle support</b>			Used in step <a href="#">48</a>
M8	Renew screws.	Tightening torque	19 Nm
<b>Top control arm to swivel bearing</b>			Used in step <a href="#">49</a>
M10	Renew screw and nut.	Tightening torque	56 Nm
<b>Spring strut holder to lower wishbone</b>			Used in step <a href="#">52</a>
M14	Renew screw and nut.	Joining torque	165 Nm
	Tighten in normal position.	Angle of rotation	90 °
<b>Brake calliper/calliper carrier to front swivel bearing</b>			Used in step <a href="#">53</a>
M12	Renew screw.	Tightening torque	130 Nm
<b>Universal joint to steering gear</b>			Used in step <a href="#">56</a>
M8	Recut screw thread.	Tightening torque	28 Nm
	Renew clamping bolt.		
	No retorquing permitted!		
<b>Connector holder for active stabilizer on side member</b>			Used in step <a href="#">57</a>
M6	Renew screw.	Tightening torque	5,8 Nm
<b>Bracket to body</b>			Used in step <a href="#">59</a>
M8		Tightening torque	19 Nm
<b>Stationary heating system on holder</b>			Used in step <a href="#">59</a>
M8		Tightening torque	19 Nm
<b>Wheel arch cover</b>			Used in step <a href="#">59</a> <a href="#">60</a> <a href="#">65</a> <a href="#">79</a>
Thermoplastic hexagon screw		Tightening torque	2,6 Nm
Plastic nut		Tightening torque	2,6 Nm
<b>Crash lever on front axle support/frame</b>			Used in step <a href="#">61</a>
M12	Renew screw.	Tightening torque	68 Nm
<b>Engine mount to engine mounting bracket</b>			Used in step <a href="#">62</a>
M12	Renew the screw and clean the thread on the engine mount.	Tightening torque	110 Nm

<b>Engine mount bracing strut on front axle support</b>			Used in step <a href="#">62</a>
M12x25		Tightening torque	108 Nm
<b>Engine mount bracing strut on body</b>			Used in step <a href="#">62</a>
M12x120		Tightening torque	108 Nm
<b>Bracing strut on engine support</b>			Used in step <a href="#">63</a>
M12x120		Tightening torque	108 Nm
<b>Bracing strut on front axle support</b>			Used in step <a href="#">63</a>
M12x25		Tightening torque	108 Nm
<b>Wheel arch cover, bottom front</b>			Used in step <a href="#">64</a>
Thermoplastic hexagon screw		Tightening torque	2.6 Nm
<b>Steering assembly cover</b>			Used in step <a href="#">66</a> <a href="#">79</a>
Thermoplastic hexagon bolt		Tightening torque	2.6 Nm
<b>Brake disc to front wheel hub</b>			Used in step <a href="#">68</a>
M8		Tightening torque	16 Nm
<b>Brake disc to rear wheel hub</b>			Used in step <a href="#">68</a>
M8		Tightening torque	16 Nm
<b>Wheel bolts</b>			Used in step <a href="#">68</a>
M 14/width across flats 17	Screw in wheel bolts and evenly apply crosswise by hand to centre the wheel rim.	Tightening torque	140 Nm
	Tighten wheel bolts crosswise to the specified tightening torque with a calibrated torque wrench.	Check	140 Nm
	Check all wheel bolts in the same order or retighten to the specified tightening torque again.		
<b>Negative battery cable to 48V battery</b>			Used in step <a href="#">75</a>
M8 nut	Threaded connections must be checked according to the four-eyes principle and documented in the vehicle records.	Tightening torque	19 Nm

**Underbody panelling/frame**Used in step [78](#) [79](#) [80](#)

Hexagon screw	Tightening torque	3 Nm
---------------	-------------------	------

**Stiffening plate to front axle support**Used in step [79](#)

M10	Renew screws.	Jointing torque	56 Nm
		Angle of rotation	90 °

**Underride protection at the front to the front axle support**Used in step [80](#)

M8	Tightening torque	19 Nm
----	-------------------	-------

**Overview of Special Tools**

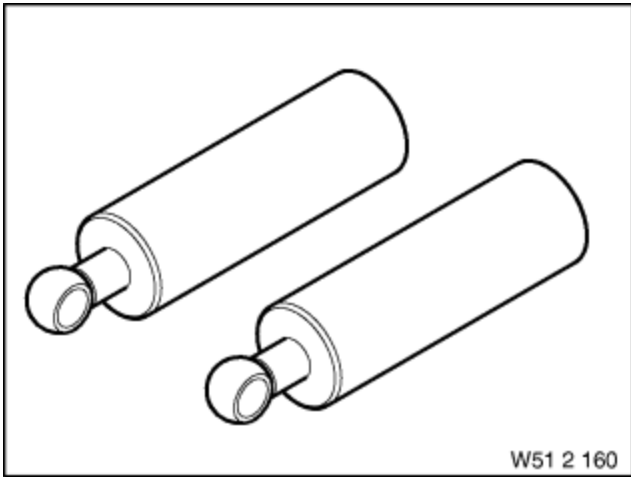
**0 493 200 (51 2 160) Support****Common**Used in step [1](#)

Usage	(Bonnet support (2 pieces)) To lock the bonnet in installation position 04/2023, it is replaced by universal support 83305A721F9
Included in the tool or work	
Storage location	C1
Replaced by	
In connection with	
SI-Number	01 02 98 (302)

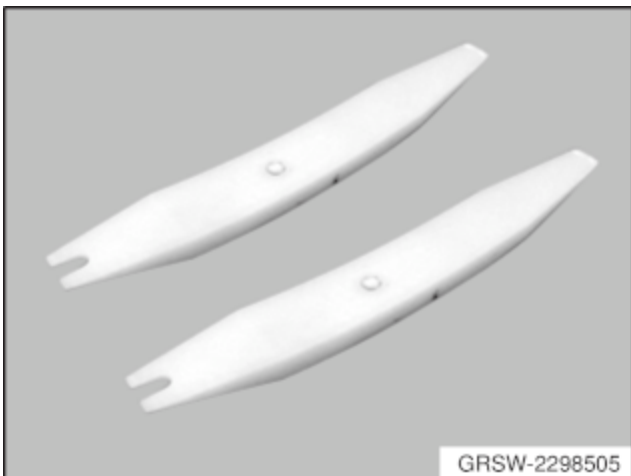
**2 298 505 Wedge****Common**Used in step [5](#) [6](#)

Usage	Kit (delivery of 2 pieces)
Included in the tool or work	
Storage location	B34
Replaced by	
In connection with	
SI-Number	01 03 12 (792)

**2 459 012 Holder****Common**Used in step [19](#) [62](#)

Usage	For removing and installing the cylinder head. Silhouette foil is included in the delivery specification.
Included in the tool or work	
Storage location	A58
Replaced by	
In connection with	

SI-Number 01 07 17 (487)

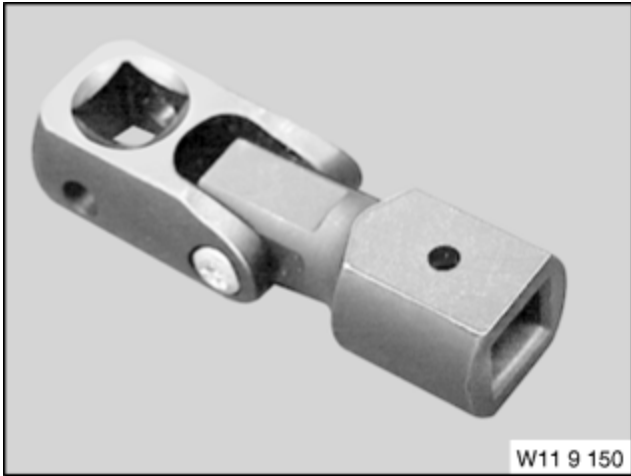
**0 493 751 (11 9 150) Extension piece****Common**Used in step [19](#) [62](#)

Usage (Socket wrench extension piece) For loosening and tightening the oxygen sensors

Included in the tool or work

Storage location C41

Replaced by

In connection with

SI-Number 01 15 00 (609)

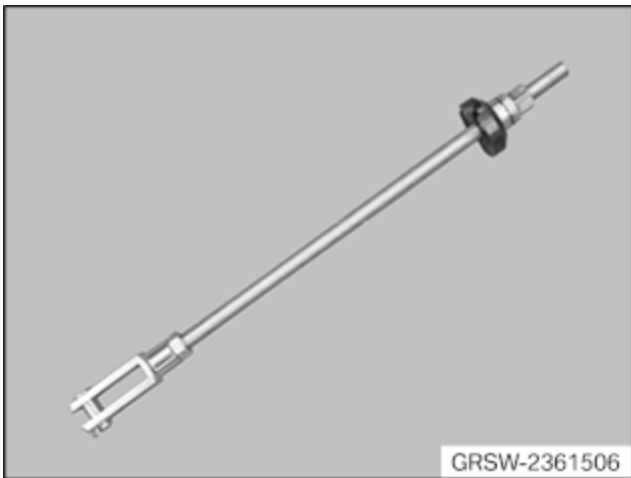
**2 361 506 (00 6 103) Spindle****Common**Used in step [19](#) [62](#)

Usage Spindle (central spindle) for Traverse 00 6 100.

Included in the tool or work 0 496 852

Storage location

Replaced by

In connection with

SI-Number 01 17 10 (659)

**2 413 317 Cable strap**Used in step [27](#) [31](#) [35](#) [53](#)



## Common

Usage

The "Cable strap" parts set consists of 3 positions as follows: ABV232 Length: 320 mm, colour: red ABV250 length: 500 mm, colour: red ABVS270 length: 665 mm, colour: red

Included in the tool or work

Storage location

Individual

Replaced by

In connection with

SI-Number 01 47 15 (332)

## 2 184 136 Mobile unit table lift

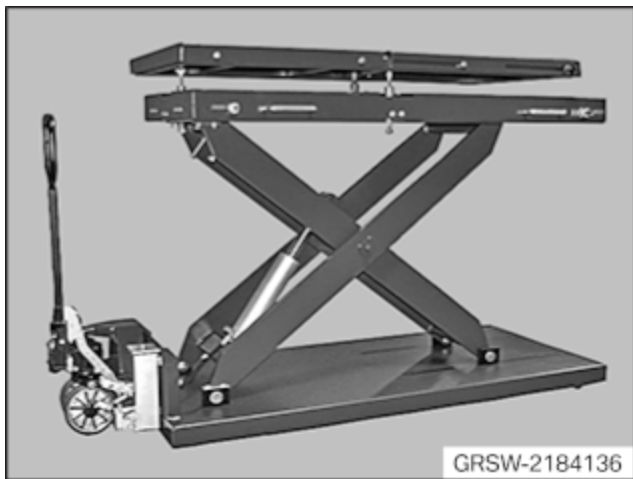

## Common

Used in step 33 34 50

Usage

Table lift MHT 1200

Included in the tool or work

Storage location

Replaced by

In connection with

SI-Number 06 01 10 (649)

## 2 305 379 Accessories



## Common

Used in step 33

Usage

Holder set for lifting table MHT 1200 and new generation (from 2020), to be replaced in 83 30 5 A68 800 = accessories and 83 30 5 A68 7A4 crossbeam separately

Included in the tool or work

Storage location

Individual

Replaced by

In connection with Mobile major assembly table lift MHT  
1200 81222184136

SI-Number 06 01 10 (649)

## 2 463 965 Socket wrench

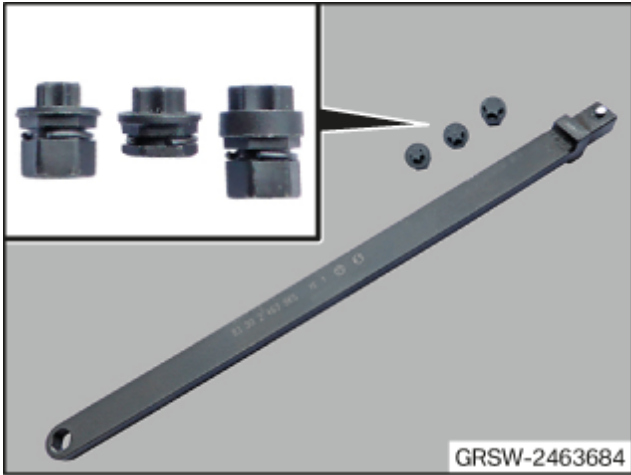

### Common

Used in step [41](#)

Usage with T30, T40 and torx 45

Included in the tool or work

Storage location B6, C6

Replaced by

In connection with

SI-Number 01 07 17 (487)

## 0 491 440 (23 0 020) Holder

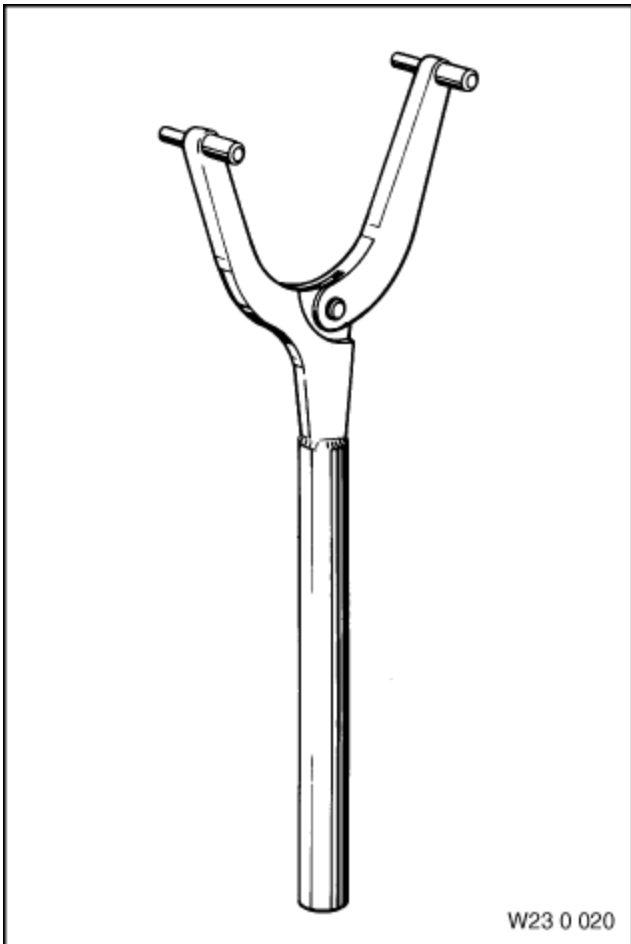

### Common

Used in step [43](#)

Usage (counter support) For all three- and four-hole flanges when releasing and tightening down

Included in the tool or work

Storage location B4, C4

Replaced by

In connection with

SI-Number

## 0 495 102 (11 4 470) Tool

Used in step [44](#)

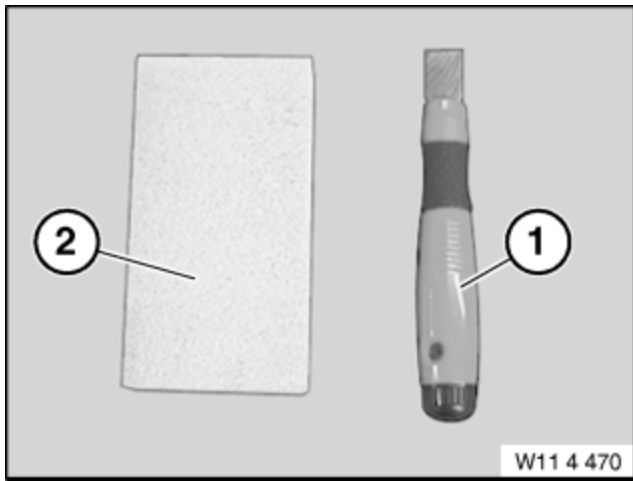

### Common

Usage	(cleaning kit) For cleaning sealing surfaces on magnesium crankcase/cylinder head.
Included in the tool or work	
Storage location	C52
Replaced by	
In connection with	
SI-Number	01 17 04 (130)

### Consisting of

Pos	BMW Order number	Replaced by	Designation	In Connection with
1	0 495 103 (11 4 471)		<b>Scraper</b>	
2	0 495 104 (11 4 472)		<b>Extractor tool (Sharpening stone)</b>	

### 2 469 803 Cartridge gun



### Common

Used in step [44](#)

Usage	For the application of the liquid sealing compound Loctite 5970.
Included in the tool or work	
Storage location	Individual
Replaced by	
In connection with	
SI-Number	01 39 18 (616)

### 0 496 120 (11 8 780) Panel

Used in step [44](#)

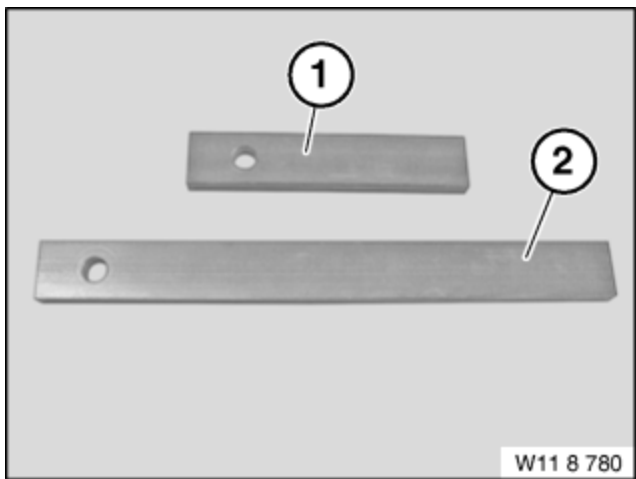

**Common**

Usage	(Mounting plates) For securing the oil sump with transmission removed.
Included in the tool or work	
Storage location	B24, C24
Replaced by	
In connection with	
SI-Number	01 05 07 (353)

**Consisting of**

Pos	BMW Order number	Replaced by	Designation	In Connection with
1	0 496 121 (11 8 781)		<b>Panel</b> (Mounting plate, short) Deleted; only available via kit 11 8 780 = 0496120.	
2	0 496 122 (11 8 782)		<b>Panel</b> (Mounting plate, long) Deleted; only available via kit 11 8 780 = 0496120.	

**5 A16 8C6 Lifting table**



**Common**

Used in step [50](#)

Usage	Mobile lifting table assembly with hydro-pneumatic stroke. Replaces MHT 1200 (81 22 2 184 136) (From 10/2022, the supplier will provide UKCA certification.)
Included in the tool or work	
Storage location	Individual
Replaced by	

In connection  
with

SI-Number 06 03 19 (699)

## 2 344 011 Tool



### Common

Used in step [68](#)

Usage

Tool (hub cap grinder) for cleaning the attachment element of the wheel rim (wheel contact face) to the wheel hub.

Included in  
the tool or  
work

Storage  
location

Replaced by

In connection  
with

SI-Number 08 08 12 (872)

## Replacement tools:

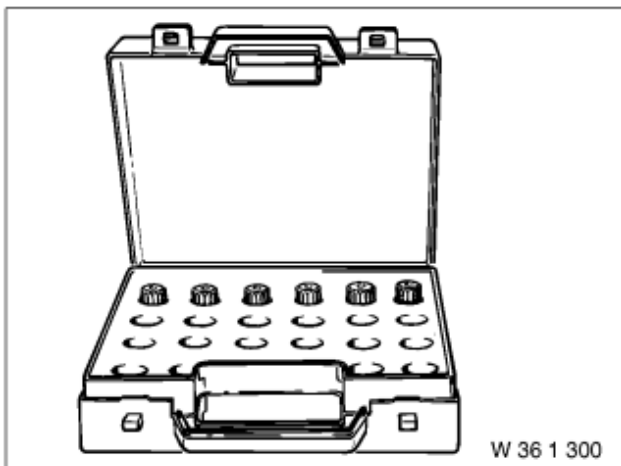
**0 495 221 (36 1 323) Wheel bolt****Common**Used in step **8**

Usage (Code 30) Code 39 available separately, (see EPC) under 36 13 1 181 259

Included in the tool or work 0 492 518

Storage location

Replaced by

In connection with

SI-Number

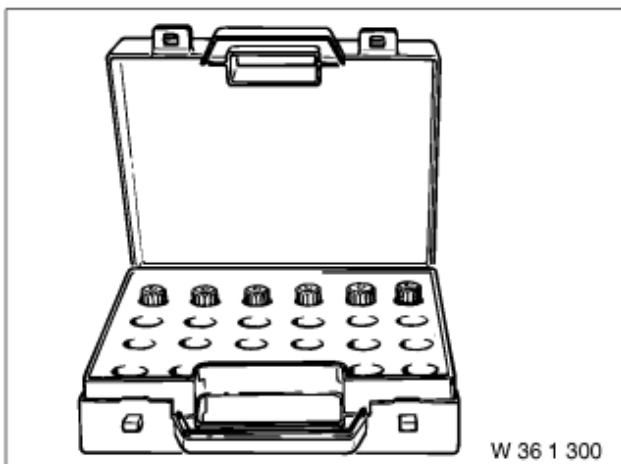
**0 495 224 (36 1 326) Wheel bolt****Common**Used in step **8**

Usage (Code 33) With centring bore available separately (see EPC) under 36 13 6 765 546

Included in the tool or work 0 492 518

Storage location

Replaced by

In connection with

SI-Number

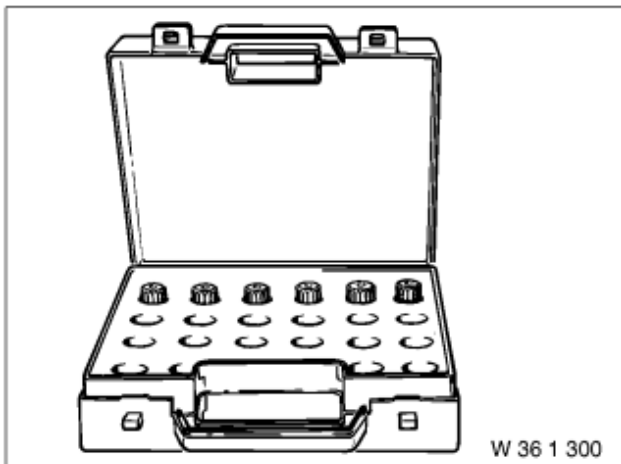
**0 495 225 (36 1 327) Wheel bolt****Common**Used in step **8**

Usage (Code 34) With centring bore available separately (see EPC) under 36 13 6 765 547

Included in the tool or work 0 492 518

Storage location

Replaced by

In connection  
with

SI-Number

### 0 495 226 (36 1 328) Wheel bolt

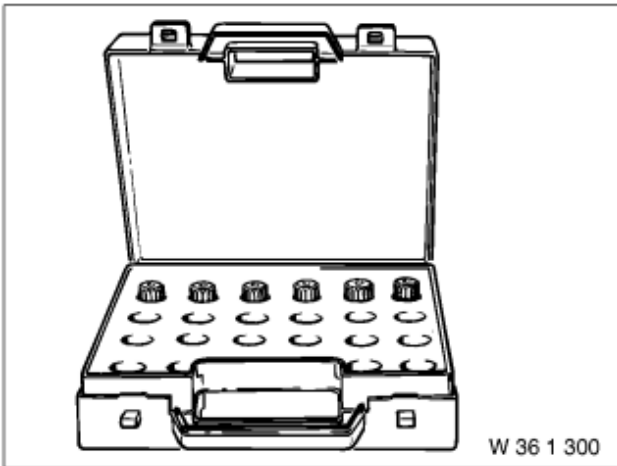

**Common**

Used in step **8**

Usage

(Code 35) With centring bore available separately (see EPC) under 36 13 6 762 340

Included in  
the tool or  
work

0 492 518

Storage  
location

Replaced by

In connection  
with

SI-Number

### 0 495 227 (36 1 329) Wheel bolt

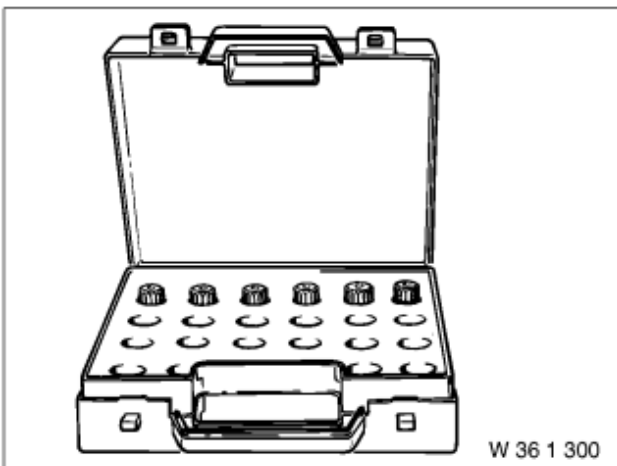

**Common**

Used in step **8**

Usage

(Code 36) With centring bore available separately (see EPC) under 36 13 6 762 341

Included in  
the tool or  
work

0 492 518

Storage  
location

Replaced by

In connection  
with

SI-Number

### 0 495 228 (36 1 331) Wheel bolt

Used in step **8**

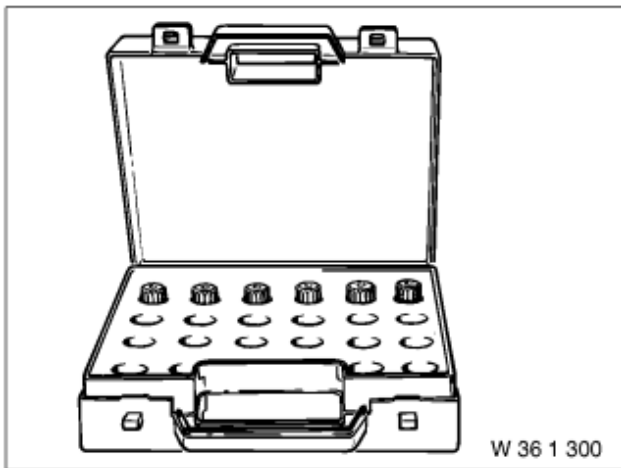

### Common

Usage	(Code 37) With centring bore available separately (see EPC) under 36 13 6 762 342
Included in the tool or work	0 492 518
Storage location	
Replaced by	
In connection with	
SI-Number	

### 0 495 229 (36 1 332) Wheel bolt

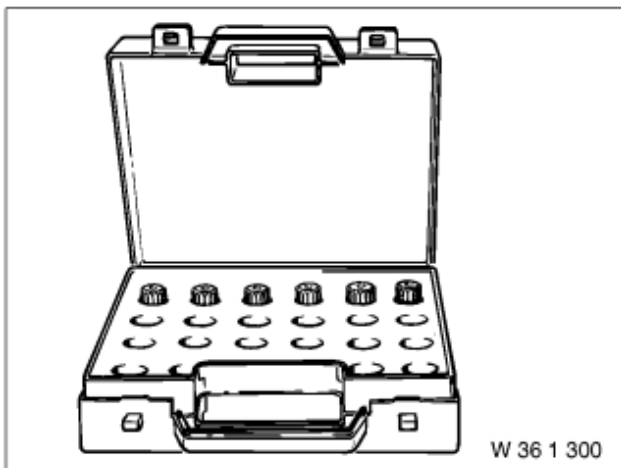

### Common

Used in step [8](#)

Usage	(Code 38) With centring bore available separately (see EPC) under 36 13 6 762 343
Included in the tool or work	0 492 518
Storage location	
Replaced by	
In connection with	
SI-Number	

### 0 495 230 (36 1 333) Wheel bolt

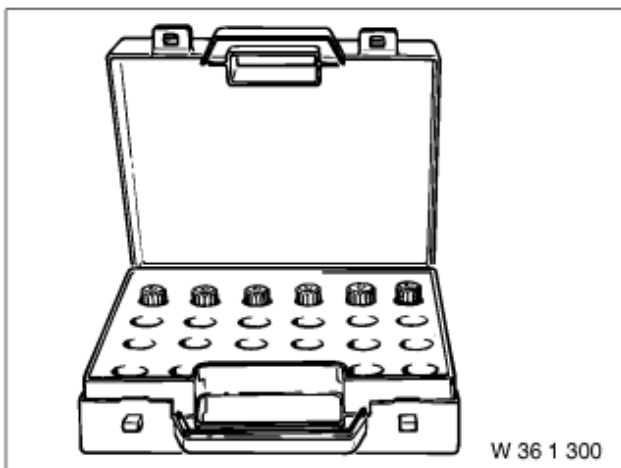

### Common

Used in step [8](#)

Usage	(Code 40) With centring bore available separately (see EPC) under 36 13 6 762 344
Included in the tool or work	0 492 518
Storage location	
Replaced by	
In connection with	

## SI-Number

**Overview Technical Data**

<b>Height of the sealing bead</b>	Used in step <a href="#">44</a>
	2,0 mm ... 2,5 mm
<b>Engine oil B58B30M1/B58B30O1</b>	Used in step <a href="#">72</a>
Capacity, engine oil change with oil filter element, <b>B58B30M1rear-wheel drive</b>	6.50 l
Capacity, engine oil change with oil filter element, <b>B58B30M1all-wheel drive</b>	6.50 l
Capacity, engine oil change with oil filter element, <b>B58B30O1rear-wheel drive</b>	6.50 l
Capacity, engine oil change with oil filter element, <b>B58B30O1all-wheel drive</b>	7.20 l
Engine oil: Technically suitable engine oils for BMW Group engines	

**Links**

<b>Overview: Technical data</b>	Used in step
<a href="#">3100 Overview of Technical Data</a>	<a href="#">52</a>
<b>Functional descriptions</b>	Used in step
<b>Repair instructions (PRE)</b>	Used in step
<b>General repair instructions</b>	Used in step
<b>Repair instructions</b>	Used in step
<b>Operating materials</b>	Used in step

**Parts****Parts required**

<b>Designation</b>	Used in step
Sealing ring	<a href="#">17</a>

Oil pump	42
Centring sleeves	43
Screw	43
Screws	43
Sealant	44
Fir tree clip	46
Screws, front	48
Screws, centre	48
Rear screws	48
Screws	48
Screw	49
Nut	49
Nut	49
Screw	49
Screw	52
Nut	52
Screw	52
Nut	52
Screw	53
Screw	53
Clamping bolt	56
Screws	57
Screws	61
Screws	61
Screws	79

For informational purposes only. The information on this website is provided AS-IS with no warranties, express or implied, and is not guaranteed to be error-free, up-to-date or complete. NewTIS and BMW assume no liability for any loss or damage arising from the use or reliance on the information and content on this website. The content on this website is subject to change without notice.